

**MODEL NUMBER:**

☐ **1662.602 Shower System Kit**

Includes:

- Fixed Hand Shower
- Hose
- Wall Supply
- Standard Slide Bar

- 1660.505
- 8888.035
- 8888.037
- 1660.225

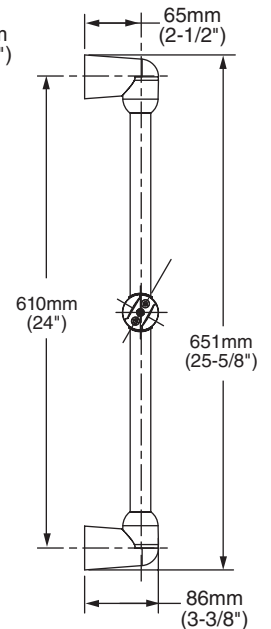
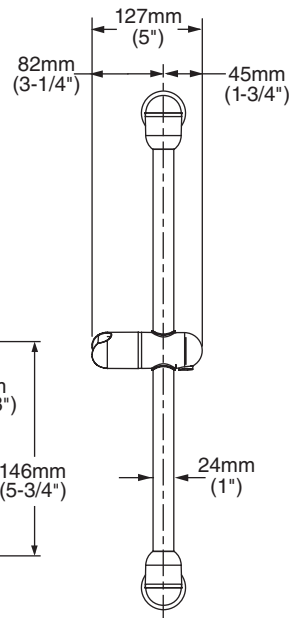
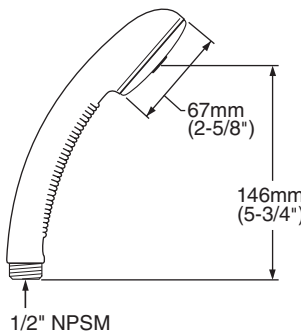
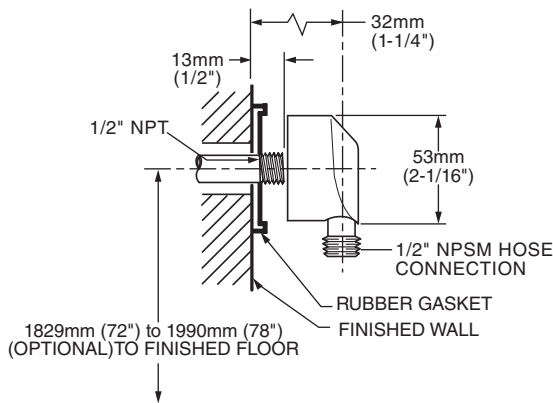

**GENERAL DESCRIPTION:**

Complete personal shower system includes: a wall supply with 1/2" NPT female inlet, 1/2" NPSM male outlet; a 59" (1500mm) shower hose; a "Fixed" hand shower; and a 25" Slide Bar. Fixed hand shower with 2.5 gpm/9.5L/min. flow restrictor. Slide bar features an adjustable shower holder which can be set at any height or position along the bar and angle up to 45°.

**PRODUCT FEATURES:**

**HAND SHOWER:**

**Lightweight, Ergonomic Design:** For a sure grip even with wet, soapy hands.

**SLIDE BAR:**

**Simple Height Adjustment:** Allows positioning of the personal shower anywhere along the bar.

**SUGGESTED SPECIFICATION:**

Shower system shall feature a wall supply with 1/2" NPT female inlets, 1/2" NPSM male outlet, 59" hose, hand shower and a 25" Standard Slide Bar. Fitting shall be American Standard Model # 1662.602.\_\_\_\_.

**CODES AND STANDARDS**

Install as required to comply with local code requirements.

**ASME A112.18.1**  
**CSA 125**

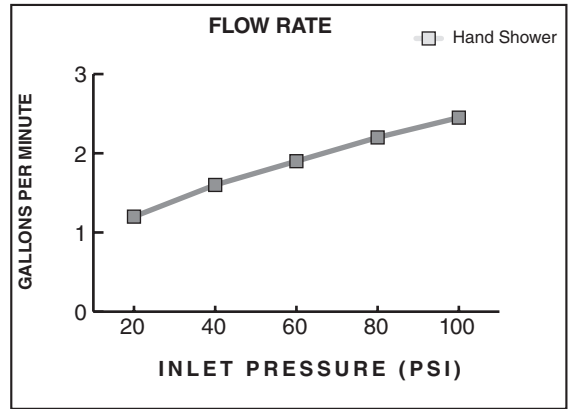

Product Number	Description	Finish
		Polished Chrome
1662.602	Shower System Kit. Contains "Fixed" hand shower, hose, wall supply and slide bar.	002