

# CAMINA MOTIF – ESTATE SERIES

inches (mm)

66 1/2 x 36 3/4 x 25 (1690 x 930 x 640) • Fax on Demand #1298

MODEL #A16636M



## FEATURES

- 7 hydrotherapy jets: pressure-flo (4), StressEaz neck and shoulder therapy (2), recessed rotary (1)
- 1.75hp pump
- Electronic on/off control
- Deep bathing well
- Slip-resistant floor
- Pre-leveled ABS support base
- Quiet pad anti-vibration pump mount
- Universal drain
- Lucite cast acrylic surface
- Limited lifetime warranty

## OPTIONS

- Chromotherapy LED lighting
- 1.5kW inline maintenance heater
- Comfort pillow: Biscuit, Black, White
- Bolt-on grab bar(s): Chrome, Oil-Rubbed Bronze, Polished Brass, Brushed Nickel, Color Matched (Biscuit, White)
- Cable drive waste & overflow: Chrome, Oil Rubbed Bronze, Polished Brass, Brushed Nickel, Color Matched (Biscuit, Bone, White)
- Optional pump location

## AQUATIC ADVANTAGE

- National distribution
- 5 manufacturing facilities
- Private fleet
- Centralized customer service
- Field support
- 24-hour fax-on-demand

## COLOR & TRIM OPTIONS

Stock	Premium
Almond (C, M)	Black (C, M)
Bone (C, M)	Cashmere (M)
Linen/Biscuit (C, M)	Mexican Sand (M)
Sterling Silver (C, M)	Red (M)
White (C, M)	Sandbar (M)

C = Color Matched Trim

M = Metallic Trim (Brushed Nickel, Chrome, Polished Brass)



# CAMINA MOTIF

66 1/2 x 36 3/4 x 25 (1690 x 930 x 640)  
inches (mm)

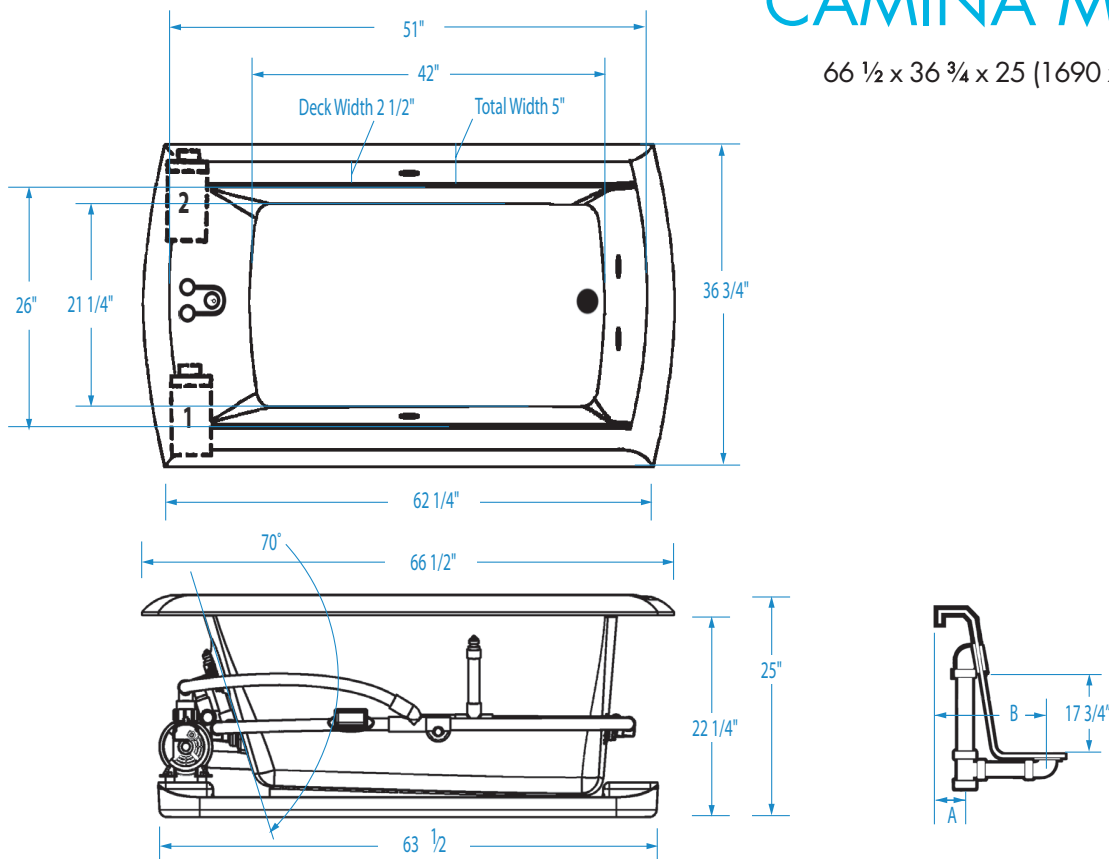

**FEATURES** lbs (kg) Dimensional Tolerance ± 3/8". Dimensions needed for site preparation should be measured from the unit. Aquatic assumes no responsibility for preparatory work.

Type and Model #	Material	Jets	Pump	Heater	Controls	Drain	Pkg. Wt.
Whirlpool #A16636M	Acrylic	7	1.75 HP	1.5 kw Inline (optional)	Electronic on/off	Universal	208 (94)

## DIMENSIONS inches (mm)

Width Overall / Net	Depth Overall / Net	Height Overall / Net	Skirt Height
66 1/2 (1690)	36 3/4 (930)	25 (635)	-

## SUMP DATA inches (mm)

Capacity to Overflow gal (ltr)	Min. Operating Capacity gal (ltr)	WIDTH @ centerline		DEPTH @ centerline	
		Top	Bottom	Top	Bottom
76 (1930)	57 (216)	51 (1295)	42 (1065)	26 1/4 (665)	21 1/4 (540)

## PLUMBING DIMENSIONS inches (mm)

A	B
5 1/2 (140)	13 1/2 (345)

## ELECTRICAL DATA

Component	Specification	Requirement
Pump	1.75 HP; 12 AMP; 110 V	15 AMP; 110V, separate circuit; Class A GFCI
Optional Heater	1.5 kW; 12.5 AMP; 110 V	15 AMP; 110V, separate circuit; Class A GFCI

**NOTES:**

1) Where applicable, utilize cut-out templates packed with unit for deck cutouts.

2) 16 x 20 (405 x 510) minimum access required at pump/blower location(s).