

# Concealed TECK® Flush Valve

**TECK®**  
COMMERCIAL

**DELTA**

## The TECK® Concealed Flush Valve is characterized for its FLEXIBILITY.

- It can be installed for back access or with a stainless steel panel for front access, reducing space for piping, etc.
- Flush valves are supplied to fit any wall from zero to 343mm (13-1/2") thick. (Note: Wall thickness does NOT have to be specified.)
- The flush valve could also be installed inside a 6" wall cavity if required.
- Each of the 3 handle actuator choices allows positioning of the Handle Control unit for a variety of desired positions. The handle can be positioned up to 6m (20') from the valve.
- Handle control tubes are flexible, color coded, copper tubes for quick, easy and proper installation.
- The handle wall flange is supplied with a stainless steel anti-rotation locking pin for vandal resistance
- A heavy gauge, plated metal wall bracket and two locknuts are supplied to insure a rigid handle control installation.

### STANDARD TECK® features:

#### WATER CONSERVATION FEATURES:

- External Volume Adjustment\*
- "Pressure Loss Check" Stop
- \*Except -48, -6, -38, -19 and -05 Models
- "Non-Hold Open" Actuators (ALSO Vandal Resistant)

#### ADDITIONAL FEATURES:

- Adjustable Tail
- CSA Certified
- Constant Peak Flow
- Copper Sweat Inlet Adaptor - 1" (3/4" on Urinal Valves)
- Vandal Resistant
- Diaphragm Type Valve
- Chloramine Resistant Diaphragm
- Forged Brass Diaphragm Retainer
- Heavy Duty
- Marine/Ship Use
- Renewable Seat
- Quiet Action
- Vacuum Breaker
- ADA Compliant  Lever Handle

See page FEA-81T for explanation of how the TECK® flush valve operates.

## ACCESS PANEL

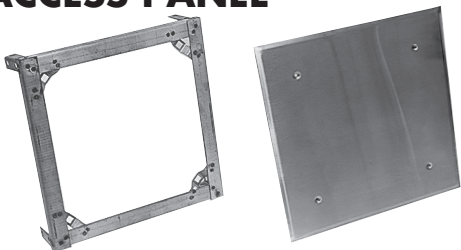

### Specifications: (example)

- 9T400 Access Panel
- 305mm (12") square frame with 365mm (14") square stainless steel cover and vandal resistant stainless steel screws.

Note: Measurements may vary  $\pm 6\text{mm}$  (0.25")

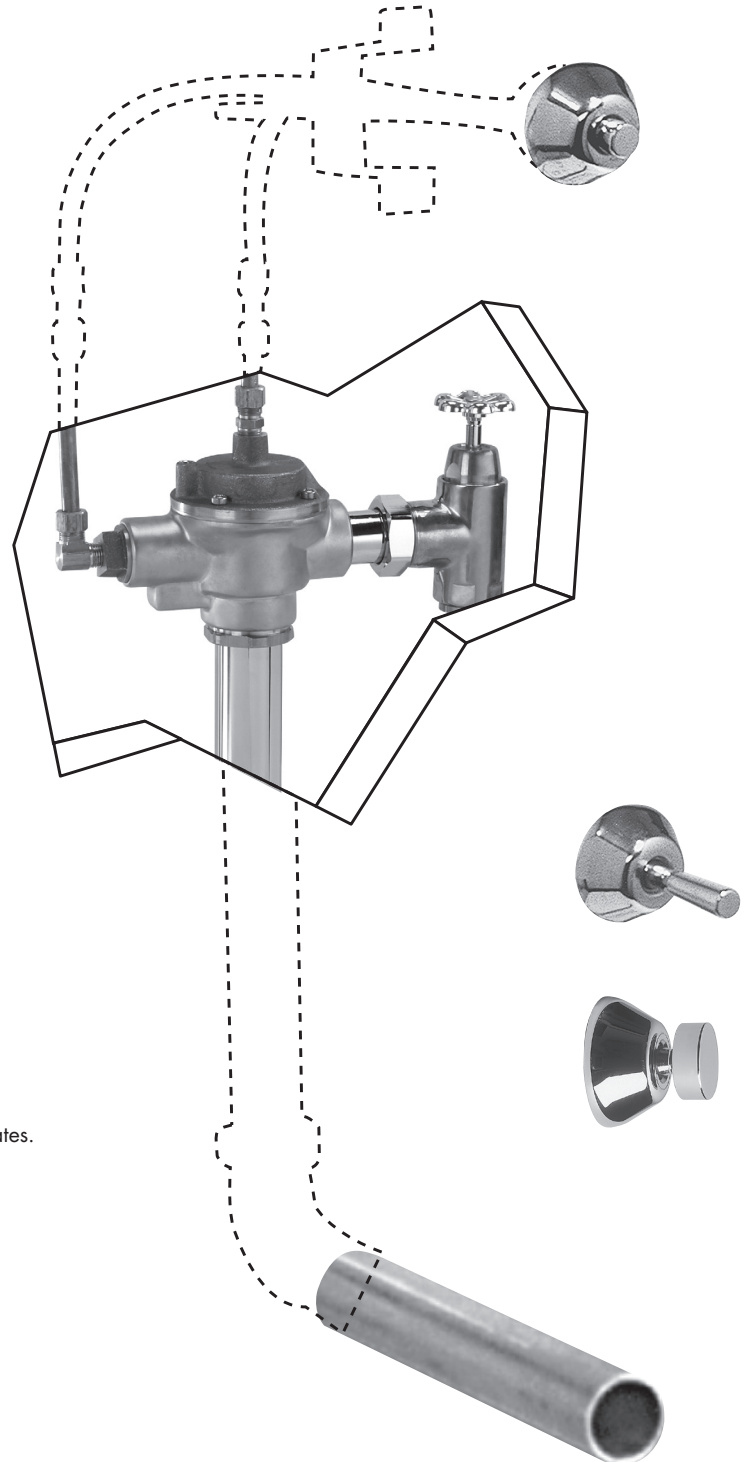

### 3 HANDLE ACTUATORS AVAILABLE

- 16mm (5/8") DIA. PUSH BUTTON
- OSCILLATING Lever Handle 
- 35mm (1-3/8") Dia. PUSH BUTTON