

Metro Octagon MEDICINE CABINET



FEATURES/TYPICAL SPECIFICATIONS

- Recess or Surface Mount Installation
 - Wall Opening/Rough-in Dimensions (for recess applications): 14 $\frac{1}{4}$ " x 24" x 4"
- Formed and welded surface design steel housing (WB/ST)
 - 1/8" thick polished edge mirror on housing back
 - 23 gauge steel with white, heat cured, acrylic paint finish
- Frameless mirror door
 - 5/32" thick float glass mirror door front with 1/2" beveled edges (1/2 BVL)
 - 24 gauge steel door back with white, heat cured, acrylic paint finish
- 125° euro style concealed hinge (HG12) (2 typical)
- Reversible for left-hand or right-hand door swing
- 3/16" thick float glass shelves, adjustable (ADJ) (3 typical)
- Snap-Fit shelf supports (20 typical)
- Includes installation hardware
- Pallet Quantity = 24 units

Finishes:

Housing: PT01—Basic White
 Mirror: 1/2 BVL -1/2" Bevel Edge
 Frame: Frameless

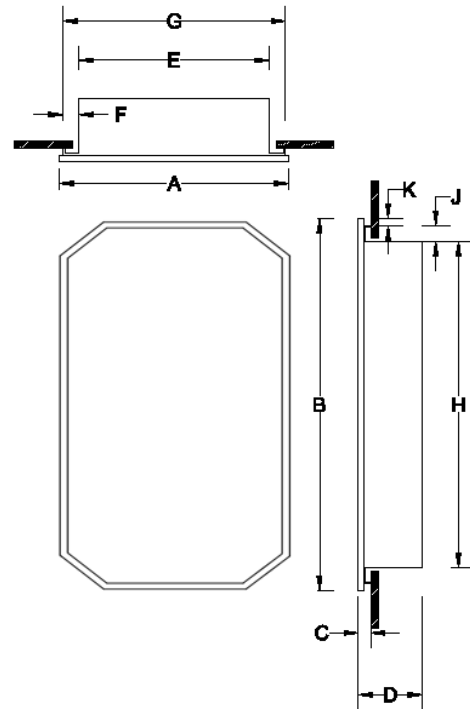

NOTE: Surface mount installation possible with optional Surface Mount Kit, 760024 (not included)

		Dimensions In Inches									
Model #	Description	A	B	C	D	E	F	G	H	J	K
52WH244PT	MEDCAB 1DR 15X31 FMLS WB/ST	15 $\frac{1}{8}$	31 $\frac{1}{4}$	1 $\frac{1}{8}$	5	13 $\frac{1}{2}$	$\frac{3}{4}$	15	23 $\frac{1}{2}$	$\frac{3}{4}$	3 $\frac{1}{8}$

REFERENCE	QTY.	REMARKS	Project
			Location
			Architect
			Engineer
			Contractor
			Submitted by
			Date

* All models and material specifications are subject to change or withdrawal without notice.