

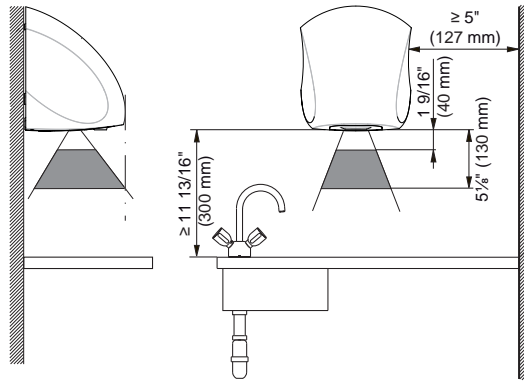

# Dimensions

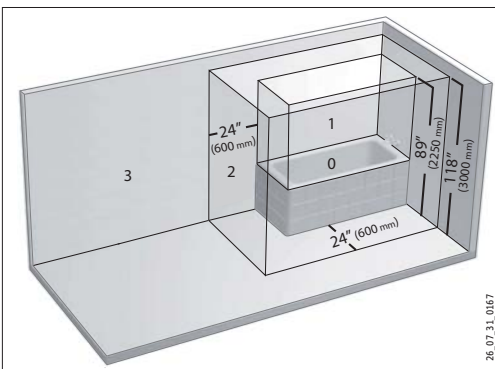
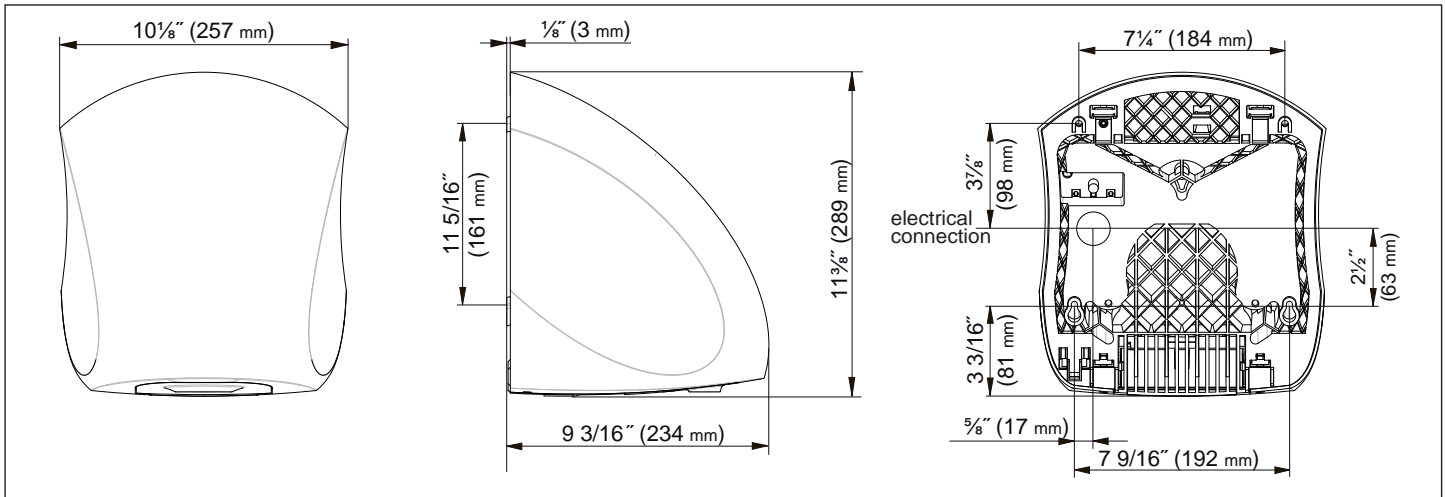

## Recommended mounting heights

Age	Age	Height
	Adult man	54" (1350 mm)
	Adult woman	48" (1250 mm)
	Preschool / kindergarten	3 - 5 32" (810 mm)
	Elementary school	6 - 10 36" (910 mm)
	Middle school	10 - 13 44" (1120 mm)
	High school	13 - 18 48" (1250 mm)

- 0 DANGER ZONE: do not install unit in bathtubs, showers, or wash basins.
- 1 DANGER ZONE: do not install directly above bathtubs or showers.
- 2 DANGER ZONE: do not install within 24" of bathtubs or showers.
- 3 SAFE AREA: unit must be installed in this area, outside of DANGER ZONES 2, 1 and 0.

# Specification

Ultronic™ hand dryers shall be manufactured by Stiebel Eltron, Inc. to include a cover of cast aluminum. Motor shall be thermally protected brush type with a single shaft. Unit shall have an IP degree of protection of 23. Dryer shall deliver 170 cubic feet per minute of air volume at an air speed of 210 mph and shall be activated by an infrared sensor automatically detecting hands when present. Hand dryer shall be listed under of ETL as conforming to ANSI/UL Std. 507 and certified to CAN/CSA Std. 22.2 No. 113.

Engineer/Architect _____	Date _____		
Job Name/Customer _____	Location _____		
Contractor _____	Representative _____		
Qty _____	kW _____	Voltage _____	Amps _____
Hand dryer model _____	_____	_____	_____