



Soft White



Driftwood Tan



Bronze – Now Available to Stock

375 Premium Floor Register

STANDARD FEATURES:

- Heavy gauge steel construction
- Individually welded 16 gauge diffusion bars
- Single blade damper on 2 1/4" height
- Opposed blade damper on 4" height
- Lever-operated multi-shutter damper on 6" height and larger
- Ability to set and lock damper for balancing
- Design protects damper operation mechanism from contact with duct work
- Rust resistant pre-coat with durable powder finish
- Driftwood Tan or Soft White

OPTIONS:

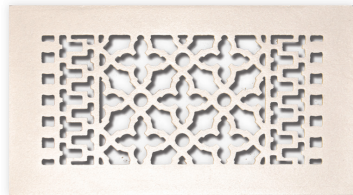
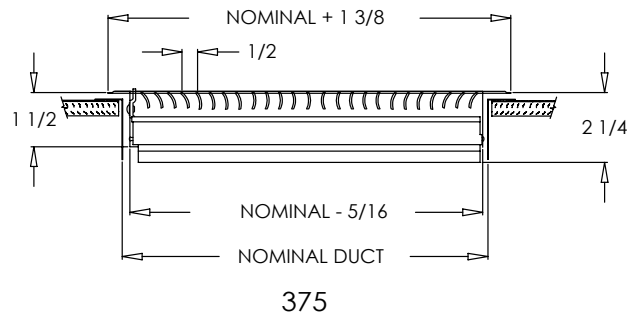
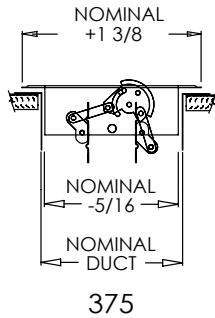

Ornamental

STANDARD FEATURES:

- Solid Cast Iron Ornamental Grilles are available in the following sizes:
 - 2 1/4 x 10, 12, 14"
 - 4 x 10, 12, 14"
 - 6 x 10, 12, 14"
- Rust resistant pre-coat with durable powder finish
- Solid edge of grille approximately 3/16" thick
- Soft White or Driftwood Tan

OPTIONS:

- Screw holes

