

NOTES

- MATERIAL: WHITE PAPER WITH LAMINATION AND PRESSURE SENSITIVE ADHESIVE.
- PRINTING: BLACK.

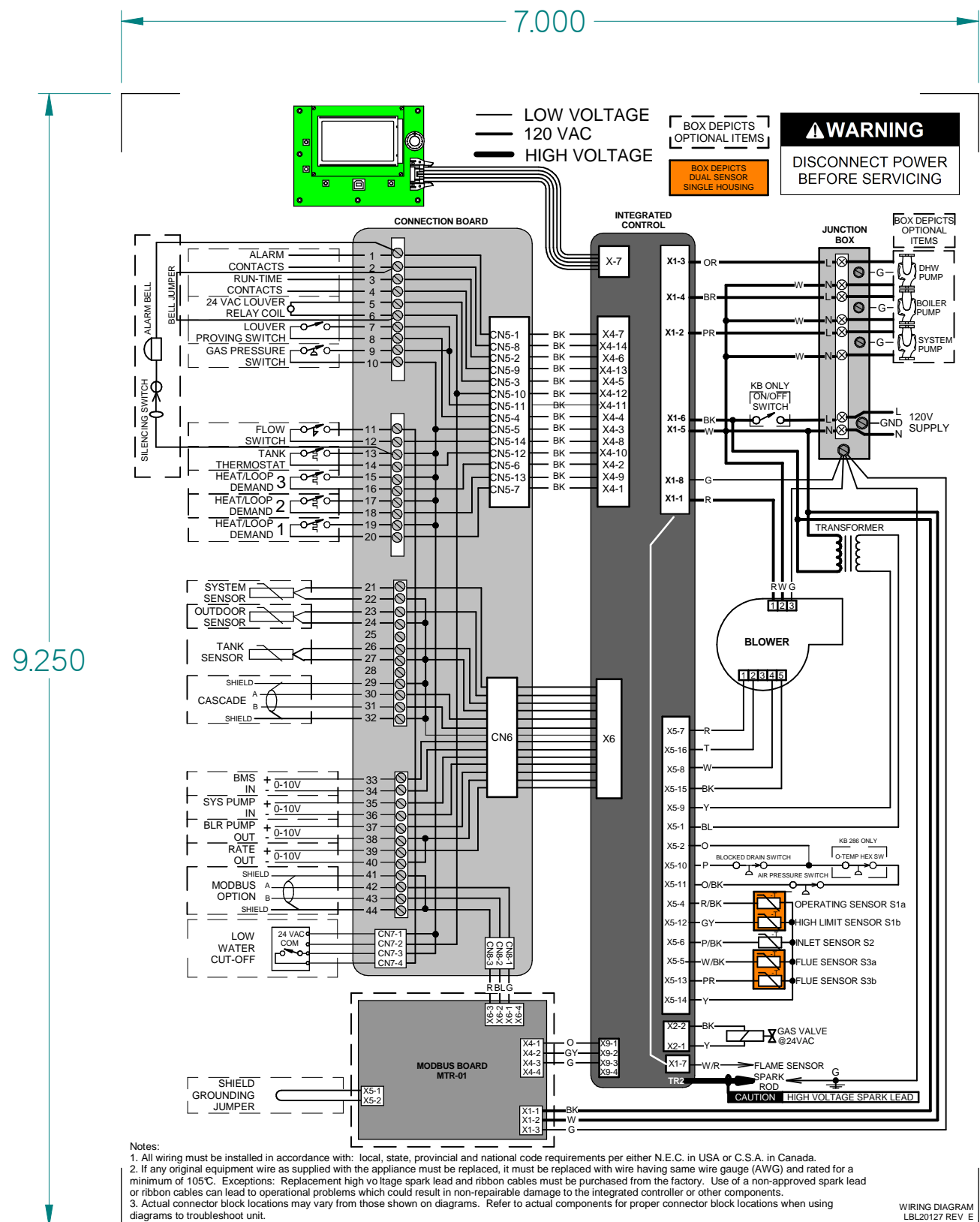

Notes:  
 1. All wiring must be installed in accordance with: local, state, provincial and national code requirements per either N.E.C. in USA or C.S.A. in Canada.  
 2. If any original equipment wire as supplied with the appliance must be replaced, it must be replaced with wire having same wire gauge (AWG) and rated for a minimum of 105°C. Exceptions: Replacement high voltage spark lead and ribbon cables must be purchased from the factory. Use of a non-approved spark lead or ribbon cables can lead to operational problems which could result in non-repairable damage to the integrated controller or other components.  
 3. Actual connector block locations may vary from those shown on diagrams. Refer to actual components for proper connector block locations when using diagrams to troubleshoot unit.

WIRING DIAGRAM LBL20127 REV. E

REV	DESCRIPTION	ECO	DATE	APR
A	INITIAL RELEASE	C05525	4/14/10	DW
B	REVISE WIRING FOR BLOCKED DRAIN AND PRESSURE SWITCHES, WIRE 13 WAS 14 IN ALARM BELL CIRCUIT	C06158	7/28/10	JM
C	ADD O-TEMP HEX SW TO INTEGRATED CONTROL X5-10 AND CONNECTION BOARD 15-20, CHANGE TO HEAT/LOOP DEMAND	C07067	9/22/10	JM
D	REVISE PER LOW VOLTAGE BOARD	C08938	10/5/11	EC
E	VOLTAGE WAS VOL TAGE	C09130	10/26/11	ERC

Drawn by: MV	Date: 2/4/10
Checked By: MC	Date: 4/14/10
Approved By: DW	Date: 4/14/10
Blank	
Material	
THIRD ANGLE PROJECTION	

UNLESS OTHERWISE SPECIFIED DIMENSIONS ARE IN INCHES FINISH IN MICROINCHES

DECIMAL  
 .X ± .125  
 .XX ± .060  
 .XXX ± .031

ANGULAR  
 ± 1°

FINISH: <sup>63</sup>/<sub>√</sub>

DEBURR AND BREAK ALL SHARP EDGES .005 MAX DO NOT SCALE THIS DRAWING

**Lochinvar, LLC**  
 300 Maddox Simpson Parkway  
 Lebanon, TN 37090  
 TEL 615-889-8900 FAX 615-547-1000  
 www.lochinvar.com  
 HIGH EFFICIENCY WATER HEATERS AND BOILERS

Title: LABEL, WIRING DIAGRAM  
 Model: KB 81-286 / WB 51-211  
 Dwg No.: LBL20127  
 REV E

SIZE B NOT TO SCALE SHEET 1 OF 1

CONFIDENTIAL  
 THIS DRAWING IS THE PROPERTY OF LOCHINVAR CORPORATION AND CAN NOT BE ALTERED, REPRODUCED OR DISTRIBUTED WITHOUT WRITTEN PERMISSION

