



# SERVICE PARTS LIST

**BULLETIN NO.**  
**54-24-6100**

SPECIFY CATALOG NO. AND SERIAL NO. WHEN ORDERING PARTS		REVISED BULLETIN	DATE
<b>1/2" HAMMER-DRILL</b>			July 2011
CATALOG NO. <b>5375-20</b>	STARTING SERIAL NO. <b>C50A</b>	WIRING INSTRUCTION <b>See Page Three</b>	

**EXAMPLE:**  
00 0 Component Parts (Small #)  
Are Included When Ordering  
The Assembly (Large #).

**SEE REVERSE SIDE FOR  
SERVICE & GREASE NOTES**

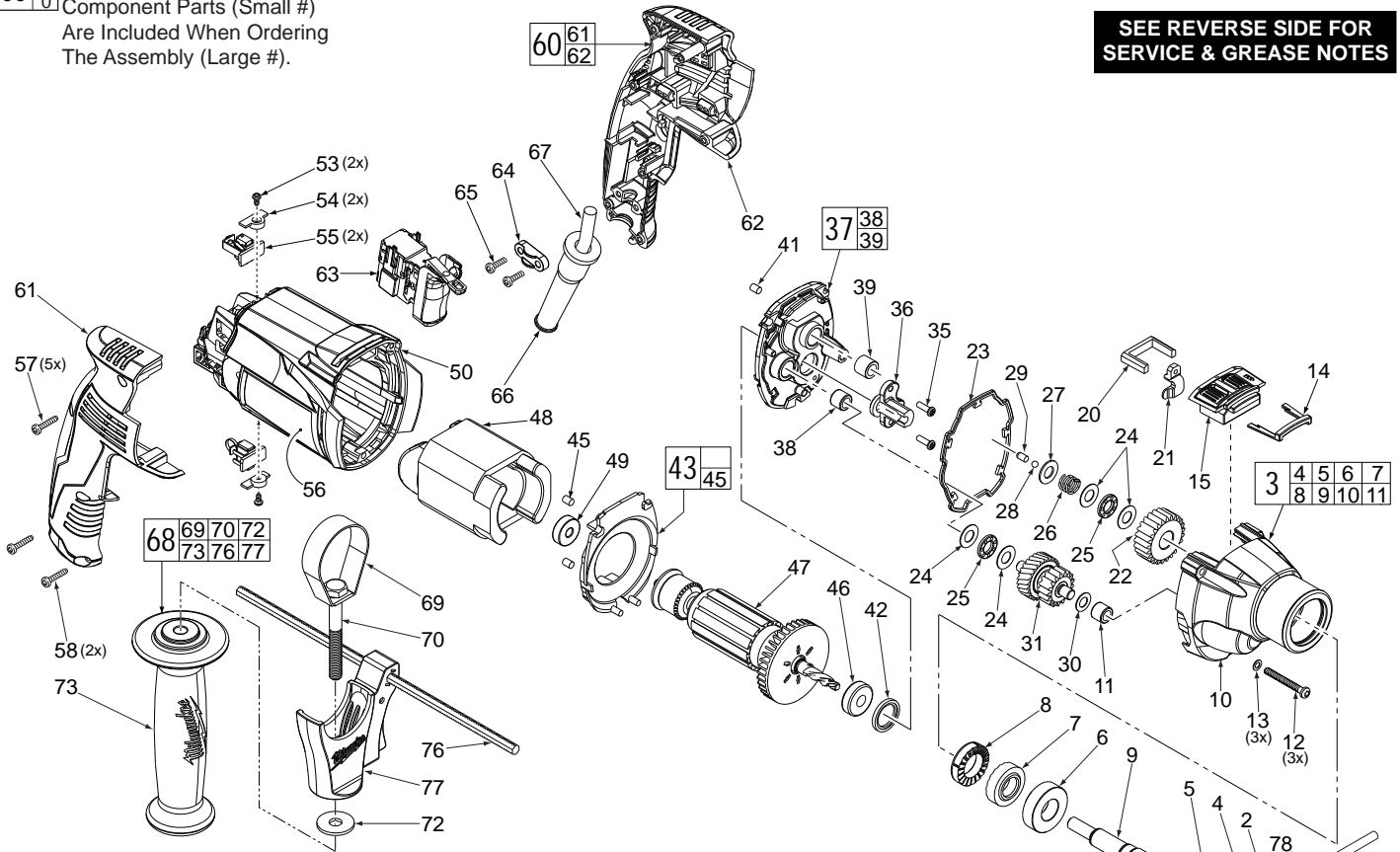

FIG.	PART NO.	DESCRIPTION OF PART	NO. REQ.
1	05-88-1500	M6 x 27 Chuck Screw	(1)
2	48-66-1356	Chuck	(1)
3	28-14-5375	Gearcase Assembly	(1)
4	34-80-5380	Retaining Ring	(1)
5	43-44-5380	Oil Seal	(1)
6	02-04-5380	Ball Bearing	(1)
7	44-84-5375	Rotating Ratchet	(1)
8	44-84-5376	Fixed Ratchet	(1)
9	38-50-5375	Spindle Shaft	(1)
10	-----	Gearcase	(1)
11	-----	Needle Bearing	(1)
12	06-81-5376	M4 x 32 ST T-20 Screw	(3)
13	45-88-0686	Spring Washer	(3)
14	43-44-5381	Rubber Seal	(1)
15	14-34-5375	Selector Housing Assembly	(1)
20	43-44-5378	Felt Seal	(1)
21	43-96-5375	Speed Selector Key	(1)
22	32-40-5375	Spindle Gear	(1)
23	43-44-5375	Gasket	(1)
24	45-88-0687	Washer	(4)
25	02-80-5380	Thrust Bearing	(2)
26	40-50-5380	Spring	(1)
27	45-88-5378	Washer	(1)
28	02-02-5380	Ball	(1)
29	44-60-5381	Pin	(1)
30	45-88-5381	Washer	(1)
31	14-29-5375	Gear Shaft Assembly	(1)
35	05-88-5380	M3.5 x 10 Screw	(2)
36	42-36-5380	Pinion Support	(1)
37	28-14-5376	Diaphragm Assembly	(1)
38	-----	Needle Bearing	(1)
39	-----	Needle Bearing	(1)
41	42-34-5380	Rubber Slug	(1)
42	43-44-5377	Seal Ring	(1)
43	14-34-5376	Baffle Assembly	(1)
45	42-34-5380	Rubber Slug	(2)
46	02-04-5375	Ball Bearing	(1)
47	16-10-5375	120V Service Armature	(1)
48	18-07-5375	120V Service Field	(1)

Apply a drop of Blue Loctite® thread locking adhesive to chuck screw (1) prior to installing onto spindle (9).

FIG.	PART NO.	DESCRIPTION OF PART	NO. REQ.
49	02-04-5376	Ball Bearing	(1)
50	31-50-5375	Motor Housing	(1)
51	23-94-5376	90mm Leadwire Assembly (Not Shown)	(1)
52	23-94-5377	55mm Leadwire Assembly (Not Shown)	(1)
53	06-81-5381	M3 x 6 Screw	(2)
54	44-66-5379	Brush Holder Retaining Plate	(2)
55	22-22-1560	120V Carbon Brush Assy. (Incl. Spring & Holder)	(2)
56	12-20-5375	Service Nameplate	(1)
57	05-88-1200	M4 x 16 Screw	(5)
58	05-88-5375	M4 x 13.5 Screw	(2)
59	23-94-5378	95mm Leadwire Assembly (Not Shown)	(1)
60	14-34-5377	Rear Handle Assembly	(1)
61	-----	Right Handle Halve	(1)
62	-----	Left Handle Halve	(1)
63	23-66-5375	120V Switch Assembly	(1)
64	31-17-0195	Cord Clamp	(1)
65	05-88-5376	M4 x 14 Screw	(2)
66	44-76-0210	Cord Protector	(1)
67	22-64-0216	Cord Set	(1)
68	14-34-5384	Side Handle Assembly	(1)
69	40-50-5379	Side Handle Clamping Band	(1)
70	05-81-5380	M8 x 53 Hex Bolt	(1)
72	45-88-5377	Washer	(1)
73	31-05-5379	Side Handle	(1)
76	44-94-5381	Depth Gauge Rod	(1)
77	14-34-5381	Side Handle Carrier Assembly	(1)
78	48-66-1357	Chuck Key	(1)
79	48-66-4040	Chuck Key Holder (Not Shown)	(1)