

OLD Optima® ETF-80/ETF-880

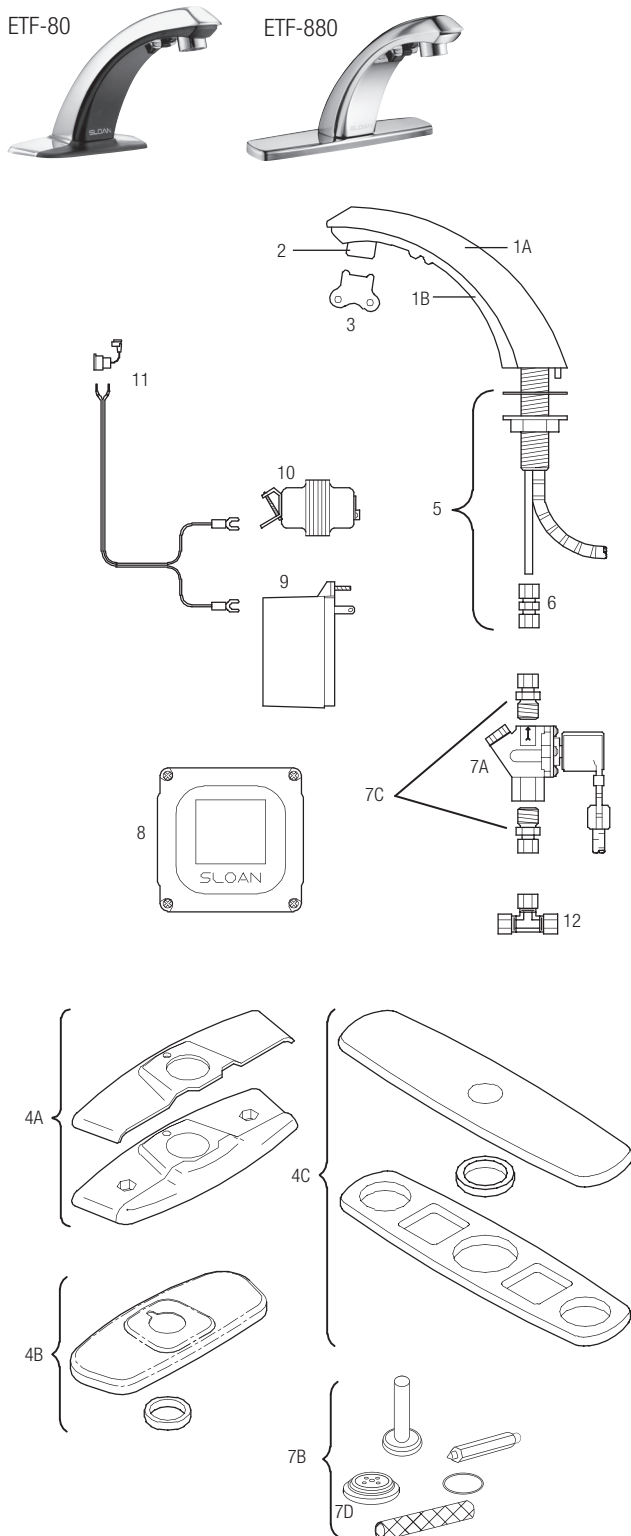

PARTS LIST—ETF-80 AND ETF-880 FAUCETS

Item No.	Code No.	Part No.	Description
1A.	0305613	ETF-250-A	Faucet/Sensor Assembly (ETF-80)
	0365054	ETF-625-A	Faucet/Sensor Assembly (ETF-880)
1B.	3365523	ETF-631-A	Sensor Assembly Only (for Faucets manufactured after 10/2003, identified by an all white Sloan name on throat plate) (ETF-80). For ETF-80 faucets prior to 10/2003 (identified by a white and red Sloan name on throat plate) sensor assembly discontinued. Use ETF-250 faucet/sensor assembly.
	OBSOLETE	ETF-1031	Repair Kit Throat Plate and Sensor (ETF-880)
2.	3365091	ETF-1021-A	0.5 gpm (1.9 Lpm) Spray Head with Key (female thread)
	3365090	ETF-1022-A	2.2 gpm (8.3 Lpm) Aerator Spray Head with Key (female thread)
	3365161	ETF-1028-A	1.5 gpm (5.7 Lpm) Laminar Flow Spray Head with Key (female thread)
	3365755	ETF-1038-A	0.35 gpm (1.3 Lpm) Multi-Lam Spray Head VR
3.	0305927	ETF-435	Replacement Key ONLY
4A.	3365466	ETF-295-A	4" (102 mm) Centerset Trim Plate Kit for Faucet (Faucet Only) includes two (2) Nuts, two (2) Hex Screws, two (2) Flat Washers, Single Hole Cover Plate, and CP Base Plate (ETF-80)
—	3365467	ETF-299-A	4" (102 mm) Centerset Trim Plate Kit for Faucet with Optional Mixing Valve includes two (2) Nuts, two (2) Hex Screws, two (2) Flat Washers, Dual Hole Cover Plate, and CP Base Plate (ETF-80)
4B.	3365473	ETF-662-A	4" (102 mm) Centerset Trim Plate Kit (CP) (ETF-880)
4C.	3365024	ETF-510-A	8" (203 mm) Centerset Trim Plate Kit includes two (2) Finger Nuts, two (2) Washer Gaskets, two (2) Fender Washers, Base Gasket, Back-up Spacer and CP Single Hole Trim Plate Assembly (CP) (ETF-880)
5.	0305626	ETF-290-A	Faucet Mounting Kit includes Rubber Gasket, Mounting Washer, Mounting Nut, and 4439071 Compression Fitting Connector
6.	0305736	ETF-297	1/4" to 3/8" Compression Fitting Connector
7A.	0305849	ETF-370-A	24 VAC Solenoid Valve Assembly includes 18" (457 mm) armored Cable and two (2) Terminal Housings
7B.	3305577	ETF-1009-A	Solenoid Valve Repair Kit includes Replacement Filter, Guide, Armature Spring, Diaphragm and Washer
7C.	3365676	ETF-437-A	Single Solenoid Supply Kit includes, two (2) Compression Fittings (Supplied only with complete faucet)
7D.	3375003	MCR-1003-A	Diaphragm only
8.	3365000	ETF-450-A	Control Module Assembly includes splashproof Junction Box and Junction Box Mounting Kit
9.	0365534	ETF-233	120V/35VA Plug-In Transformer
10.	0345370	EL-248-40	24V/40 VA Box Mount Transformer
11.	0365001	ETF-458-A	Input Power Cable (Transformer to Control Module) includes Strain Relief and two (2) Terminal Crimp Connectors
12.	3365461	ETF-617-A	Bak-Chek® Tee Assembly
—	3305560	ETF-1006-A	Repair Kit for old-style ETF-80 Faucets (manufactured before 1992) includes Hex Screw, 5/64" Hex Wrench, Cable Assembly, Hose Clamp, 5-connector Housing, Key for Spray Heads, Access Plate/Sensor Assembly, and Control Module Assembly — OBSOLETE

OLD-STYLE FAUCETS

ETF-80 faucets manufactured before 1992 had all their electronic circuitry located within the body of the spout.

Replacement parts (including sensor components) are available in repair kits ETF-1006-A. — **OBSOLETE**

See page 157 for faucet cable extension cords.

— = Not shown in illustration

OLD Optima® ETF-80/ETF-880**TROUBLESHOOTING GUIDE****1. No water is delivered when faucet is activated.**

INDICATOR: If no LED lights illuminate:

- A. No electricity is being supplied to faucet. Ensure that the main power is turned "ON". Check all transformer, sensor, solenoid and cable connections. Make sure that transformer is supplying 24 VAC (Volts AC). If no voltage is detected, replace transformer.
- B. There is an electrical system malfunction. Reset electrical system. Unplug Sensor connection. Disconnect power to circuit for ten (10) seconds. Reconnect.

INDICATOR: If the GREEN LED illuminates when power is reconnected:

- C. There is a short in the sensor. Replace sensor. Refer to individual faucet parts diagram for appropriate sensor assembly. **NOTE:** GREEN LED may illuminate immediately after sensor disconnection.
- D. There is a short in the solenoid or solenoid cable. Replace ETF-370-A solenoid.

INDICATOR: If the GREEN LED does NOT illuminate when power is reconnected:

- E. There is an electrical system malfunction. Reset electrical system. Unplug sensor connection. Disconnect power to circuit for ten (10) seconds. Reconnect.
- F. The control module circuit is not working properly. Replace ETF-450-A control module.

INDICATOR: If GREEN LED illuminates AND changes to RED when hands are in the sensor's detection zone AND the RED solenoid LED illuminates:

- G. Water supply stop(s) may be partially closed. Open stop(s) if closed.
- H. Debris is clogging solenoid filter. Shut off water supply. Remove, clean and reinstall solenoid filter.

INDICATOR: If GREEN LED illuminates AND changes to RED when hands are placed in the sensor's detection zone AND the RED solenoid LED flickers with a vibrating/clicking noise heard inside the module: Note: Applies only to REVISION 2 MODULES.

- I. There is a direct short in the solenoid or solenoid cable. Replace with ETF-370-A solenoid.

INDICATOR: If GREEN/RED LED illuminates AND changes to RED when hands are NOT located in the sensor's detection zone BUT the RED solenoid LED (in upper left corner of circuit) does NOT illuminate:

- J. Sensor range is set too long and is detecting the sink. Reduce sensor detection range.
- K. Sensor is not working properly. Replace sensor. Refer to individual faucet parts diagram for appropriate sensor assembly.

INDICATOR: If GREEN LED illuminates BUT does NOT change to red when hands are placed in the sensor's detection zone:

- L. Sensor range is set too short. Increase sensor detection range.
- M. Sensor is not working properly. Replace sensor. Refer to individual faucet parts diagram for appropriate sensor assembly.

2. Sensing range is too short.

- A. Extended range sensitivity is required. Dip switch number 4 should be in the "DOWN" (extended range sensitivity) position. Increase range

by adjusting range potentiometer clockwise (yellow phillips screw in blue base).

- B. Faucet has surgical bend gooseneck spout. For long range use (recommended for surgical bend gooseneck spout faucet models), remove range jumper from upper right hand corner of circuit board. Adjust range potentiometer. **NOTE:** Applies only to REVISION 2 MODULES.

3. Faucet activates by itself (false triggers).

- A. Sensor range is set too long. Decrease range by adjusting range potentiometer counterclockwise. If necessary, flip dip switch number 4 into the "UP" (reduced range sensitivity) position. Check surroundings for factors that contribute to sensor range detection problems (bright lights, highly reflective surfaces, sunlight, etc.).

4. Faucet delivers very low flow or just a dribble.

- A. Water supply stop(s) may be partially closed. Open stop(s).
- B. Debris is clogging solenoid filter. Shut off water. Remove, clean, and reinstall solenoid filter.
- C. Solenoid is worn or not working properly. Rebuild with ETF-1009-A solenoid repair kit or replace ETF-370-A solenoid.
- D. Debris is clogging faucet aerator or spray head. Shut off water. Use key if required to remove. Then clean and reinstall aerator or spray head.

5. Faucet DOES NOT stop delivering water or continues to drip after user is no longer detected (even after power to the module has been disconnected).

- A. Solenoid valve is installed backward. Disconnect solenoid. Reconnect solenoid with water flow towards the faucet (see arrow on solenoid).
- B. Debris is clogging solenoid. Remove and clean solenoid operator. If necessary, rebuild with ETF-1009-A repair kit.
- C. Seat in solenoid valve body is damaged or pitted. Replace with ETF-370-A solenoid.

When assistance is required, please contact Sloan Technical Support at: 1-888-SLOAN-14 (1-888-756-2614).