

UPSP SERIES - 1/2 HP

APPLICATIONS

Pressure boosting for washing vehicles, flooded basements, watering lawns, draining water heaters

FEATURES

- Non-submersible, inline, portable utility transfer pump with rugged one-piece cast iron housing and integral carrying handle
- Self-priming to 15 ft (4.6 m) when priming chamber is filled
- Can also be used to boost water pressure for washing vehicles, sidewalks, and more
- Convenient 3/4" (19 mm) brass garden hose adapters on intake and discharge
- Engineered thermoplastic impeller
- 3/4" (19 mm) FNPT discharge
- 140 °F (60 °C) liquid temperature rating
- cCSAus listed



SERIES SPECIFICATIONS

Volts	Hz	Amps		Watts	Performance (GPH @ Height in Feet)					Shut-Off (ft)	PSI
		FLA	Start		20'	40'	60'	80'	100'		
115	60	9	25	900	1152	912	648	372	90	105	45.4

Item No.	Model	Volts	Operation	Cord	Weight
555101	UPSP-5	115	Self-Priming	10' 3 m	17.8 lbs 8.07 Kg

UTILITY PUMPS

UPSP SERIES - 1/2 HP

ENGINEERING DATA

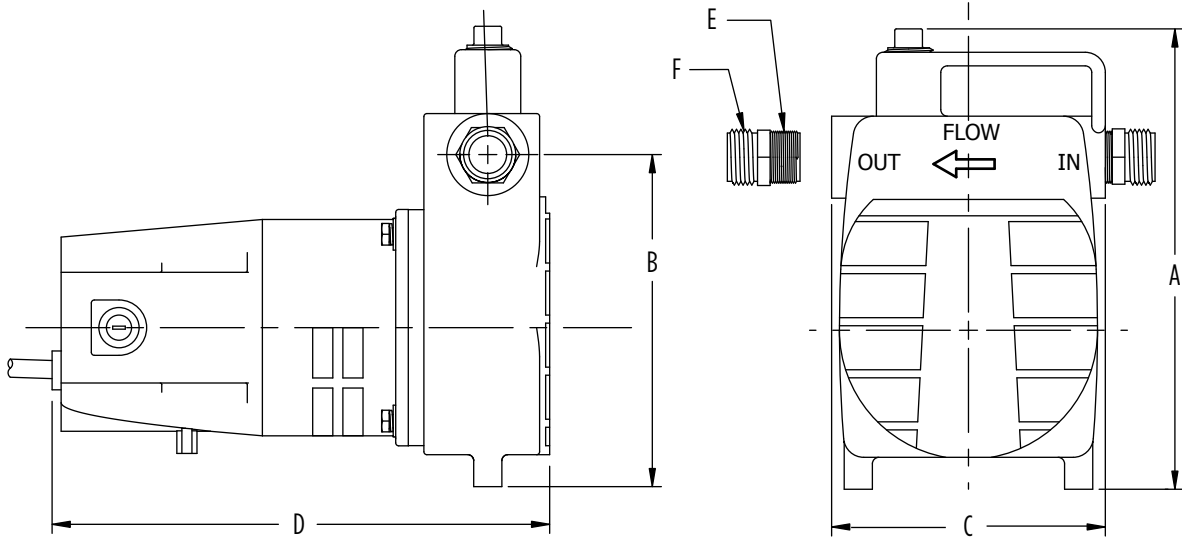

A	B	C	D	E	F
9.15"	6.6"	5.5"	9.9"	3/4" MNPT	3/4" MGHT
23.24 cm	16.76 cm	14 cm	25.15 cm	1.91 cm	1.91 cm

PERFORMANCE DATA

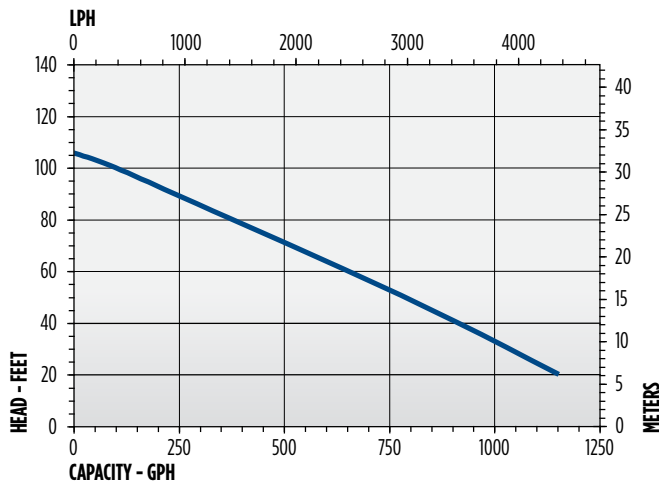

CONSTRUCTION

Motor Housing	Cast iron
Impeller Material	Thermoplastic
Impeller Type	Semi-open
Volute	Cast iron
Motor Shaft	Carbon steel
Shaft Seal	Carbon/ceramic
Fasteners	Stainless steel
Bearings	Front and back ball bearings
Power Cord	SJT