



see what Delta can do™

92519

TOUCH₂O® PULL-OUT KITCHEN & BAR/ PREP FAUCET LLAVE DE AGUA/GRIFO EXTRAÍBLE TOUCH₂O® PARA COCINAS Y FREGADEROS PARA PREPARATIVOS/ BARES

ROBINET TOUCH₂O® À BEC RÉTRACTABLE POUR ÉVIER D'ÎLOT, DE BAR ET DE CUISINE

Models/Modelos/Modèles
**CASSIDY™, DOMINIC®, ESSA®,
MATEO®, TRINSIC® & TRASK™**

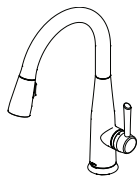

9113T-DST▲
9913T-DST▲

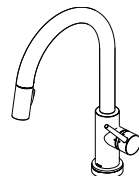

9159T-DST▲
9959T-DST▲

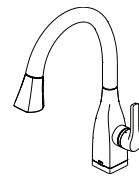

9183T-DST▲
9983T-DST▲

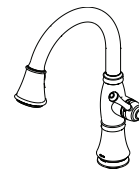

9197T-DST▲
9997T-DST▲

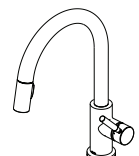

19933T-DST▲

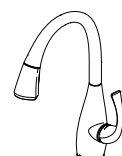

19940T-DST▲

Write purchased model number here.
Escriba aquí el número del modelo comprado.
Inscrivez le numéro de modèle ici.

You may need/Usted puede necesitar/Articles dont vous pouvez avoir besoin:

3/32"

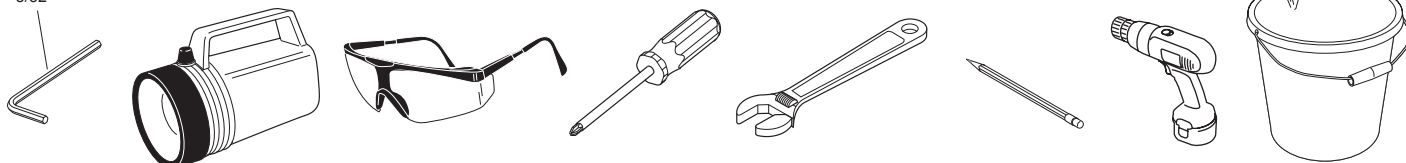

For easy installation of your Delta® faucet you will need:

- To **READ ALL** the instructions completely before beginning.
- To **READ ALL** warnings, care, and maintenance information.

Para instalación fácil de su llave Delta® usted necesitará:

- **LEER TODAS** las instrucciones completamente antes de empezar.
- **LEER TODOS** los avisos, cuidados, e información de mantenimiento.

Pour installer votre robinet Delta® facilement, vous devez:

- **LIRE TOUTES** les instructions avant de débiter;
- **LIRE TOUS** les avertissements ainsi que toutes les instructions de nettoyage et d'entretien.

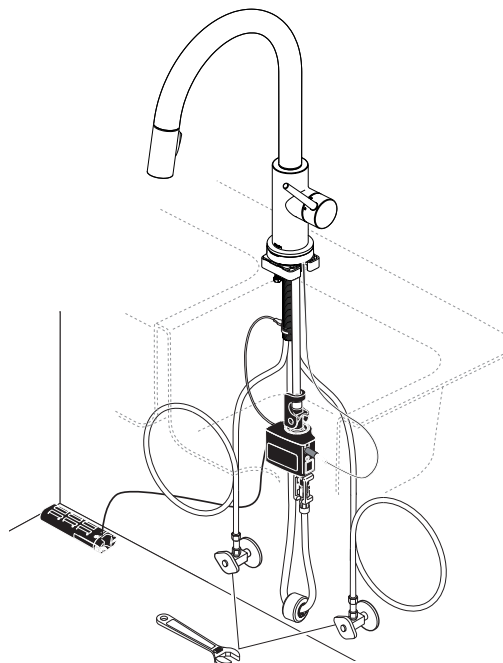

To access additional technical documents & product info, visit www.deltafaucet.com/p/Your-Model-Number-Here (example: www.deltafaucet.com/p/9159T-DST)
Para acceder a documentos técnicos adicionales e información sobre el producto, visítenos en www.deltafaucet.com/p/Your-Model-Number-Here (ejemplo: www.deltafaucet.com/p/9159T-DST)
Pour avoir accès à des documents techniques supplémentaires et à de l'information sur le produit, visitez www.deltafaucet.com/p/Votre-numéro-de-modèle-ci (exemple : www.deltafaucet.com/p/9159T-DST)



www.deltafaucet.com
1-800-345-DELTA (3358)
customerservice@deltafaucet.com

EP92546
Solenoid Assembly
Ensamble de Solenoide
Électrovanne

For PC, SS, AR & KS finishes, order **EP92546**
For PL, MW, RB & SP finishes, order **EP92546XX**

Para acabados PC, SS, AR y KS, ordene **EP92546**
Para acabados PL, MW, RB y SP, ordene **EP92546XX**

Pour les finis PC, SS, AR et KS, commandez **EP92546**
Pour les finis PL, MW, RB et SP, commandez **EP92546XX**

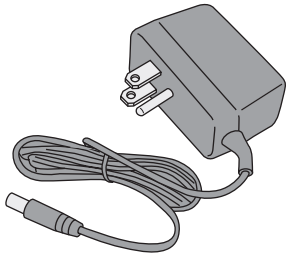

EP73954
9 Volt Power Supply
(Accessory Order Only)
Fuente de alimentación de 9 voltios
(Orden de accesorios solamente)
Alimentation électrique 9 volts
(L'accessoire seulement)

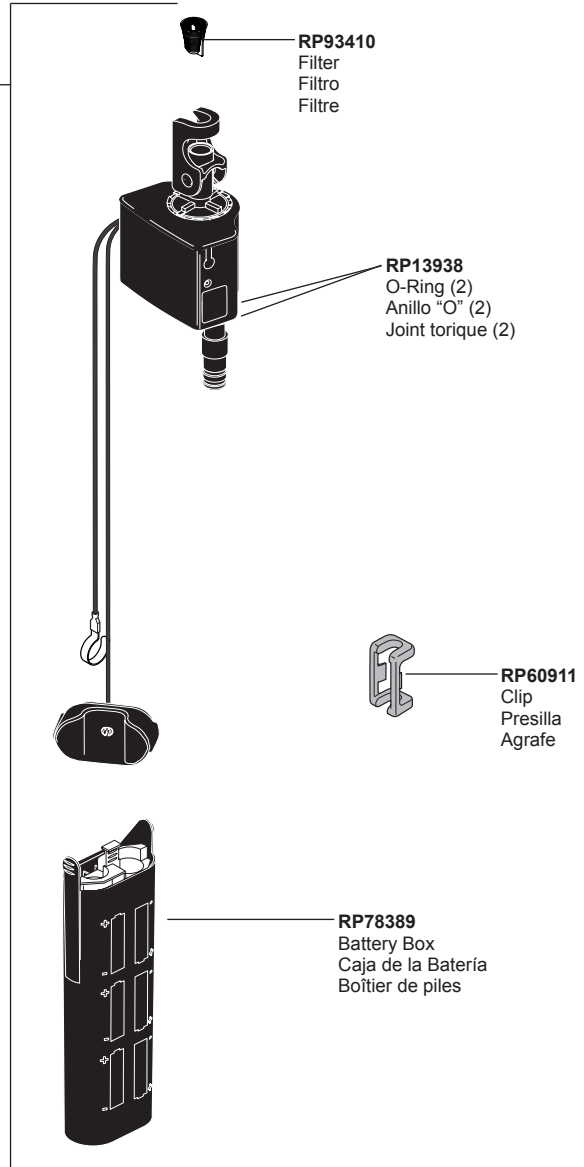

RP93410
Filter
Filtro
Filtre

RP13938
O-Ring (2)
Anillo "O" (2)
Joint torique (2)

RP60911
Clip
Presilla
Agrafe

RP78389
Battery Box
Caja de la Batería
Boîtier de piles

Other useful accessories that may be purchased separately.
Otros accesorios útiles que se pueden comprar por separado.
Autres accessoires utiles pouvant être achetés séparément.

RP63263

Adapters
3/8"-24 UNEF to 1/2"-20 UN &
3/8"-24 UNEF to 1/2"-14 NPSM
Adaptadors
3/8"-24 UNEF a 1/2"-20 UN &
3/8"-24 UNEF a 1/2"-14 NPSM
Adpteurs
3/8 po-24 UNEF à 1/2 po-20 UN et
3/8 po-24 UNEF à 1/2 po-14 NPSM

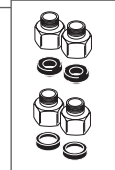

RP63264

Adapters (10) 3/8"-24 UNEF to 1/2"-20 UN
Adaptadors (10) 3/8"-24 UNEF a 1/2"-20 UN
Adpteurs (10) 3/8 po-24 UNEF à 1/2 po-20 UN



RP63265

Adapters (10) 3/8"-24 UNEF to 1/2"-14 NPSM
Adaptadors (10) 3/8"-24 UNEF a 1/2"-14 NPSM
Adpteurs (10) 3/8 po-24 UNEF à 1/2 po-14 NPSM

