



SERVICE PARTS LIST

BULLETIN NO.
54-26-2810

SPECIFY CATALOG NO. AND SERIAL NO. WHEN ORDERING PARTS		REVISED BULLETIN	DATE
M18™ FUEL™ 1/2" Square Impact Wrench			Sept. 2016
CATALOG NO.	2861-20	WIRING INSTRUCTION	
	STARTING SERIAL NO. H62A	SEE PAGE 2	

FIG.	PART NO.	DESCRIPTION OF PART	NO. REQ.
1	06-82-2366	M5 x 26.5mm Pan Hd. ST T-25 Screw	(4)
2	28-50-0021	Gearcase Assembly	(1)
3	45-88-0101	Plastic Gearcase Washer	(1)
4	44-90-4530	Friction Ring	(1)
5	34-40-0900	O-Ring	(1)
6	-----	1/2" Square (Friction Ring) Anvil	(1)
7	02-02-7010	7/32" Steel Ball	(1)
18	34-40-0067	O-Ring	(1)
24	02-04-0330	Ball Bearing	(1)

EXAMPLE:
Component Parts (Small #)
Are Included When Ordering
The Assembly (Large #).

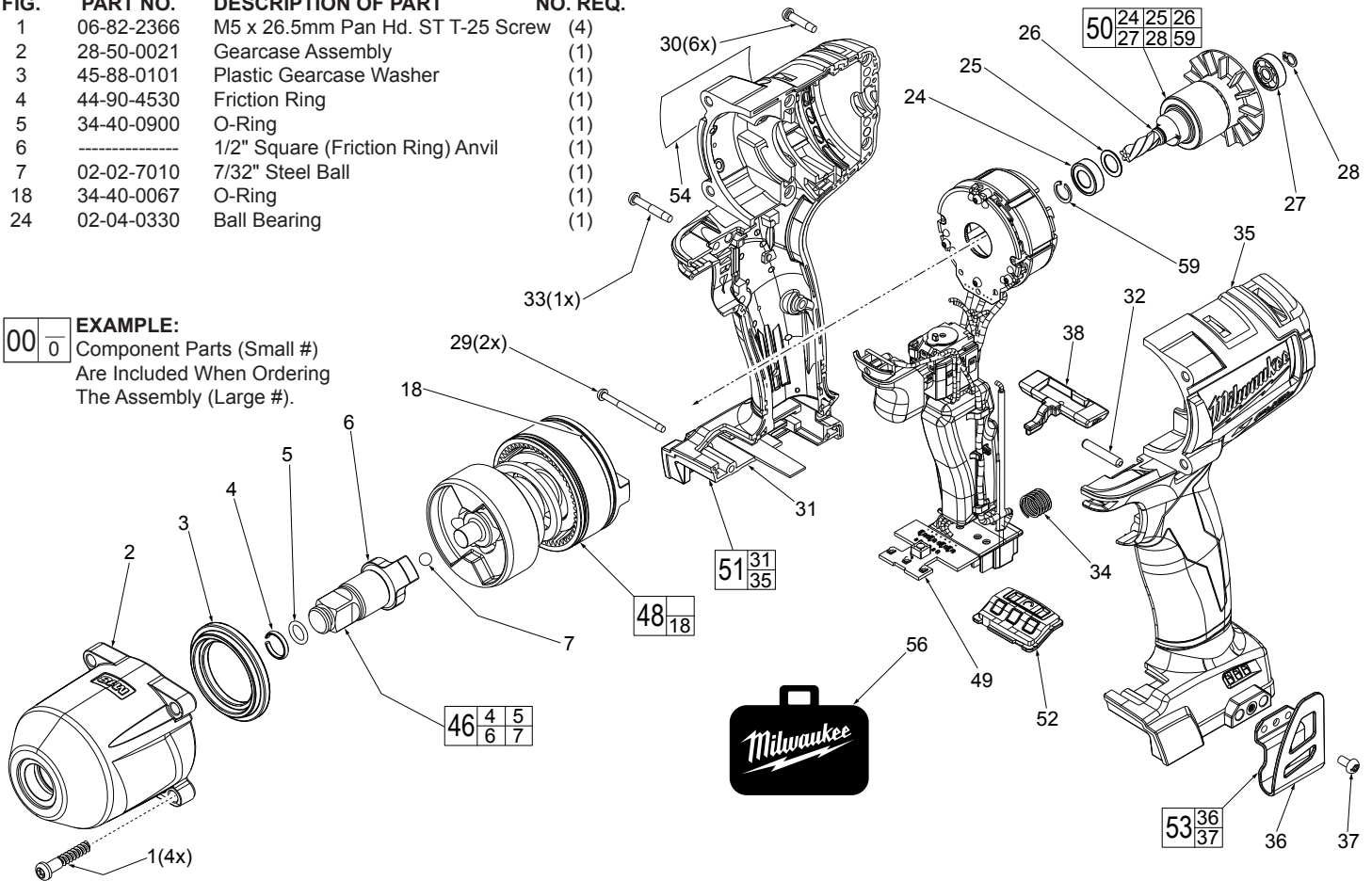
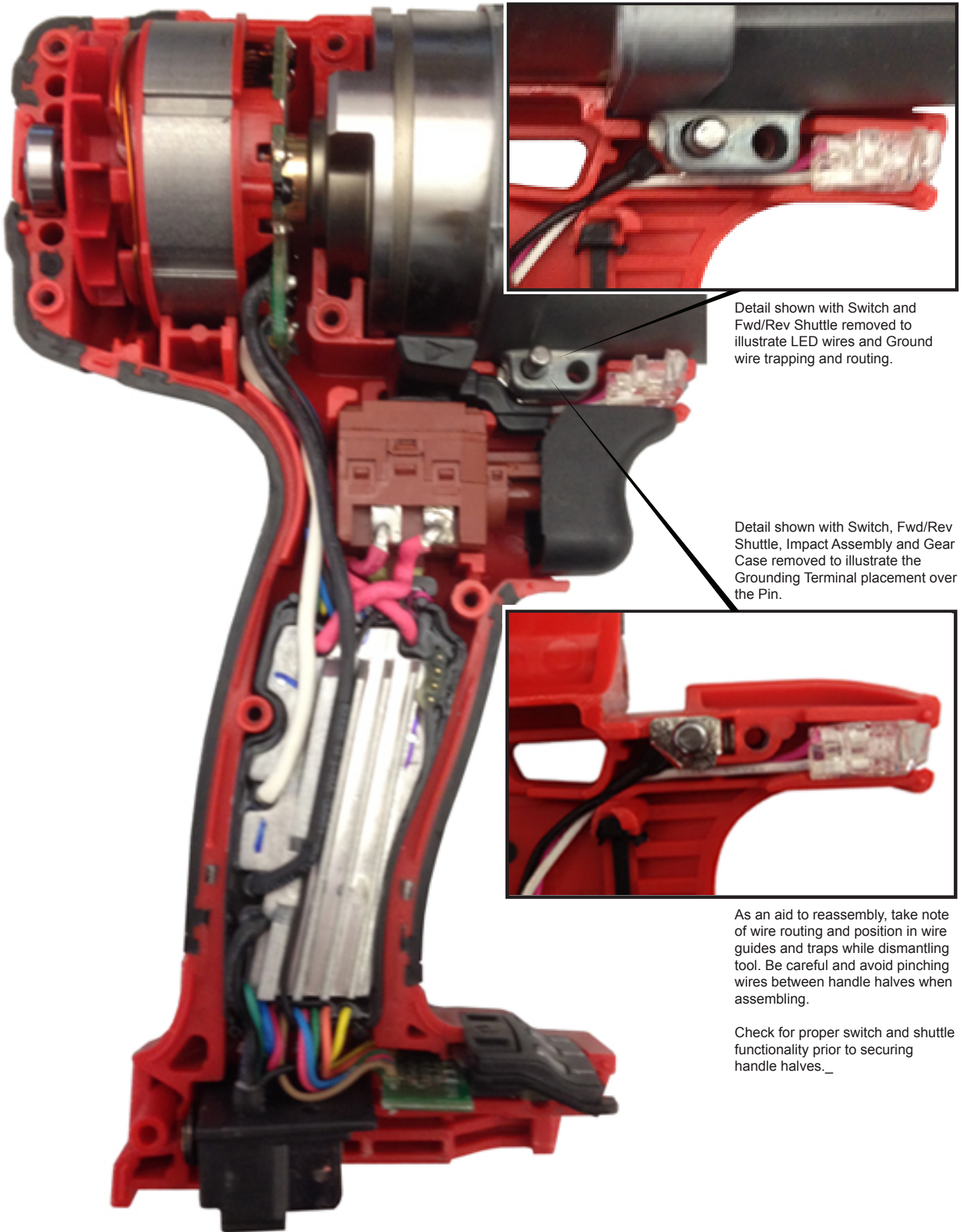

FIG.	PART NO.	DESCRIPTION OF PART	NO. REQ.
25	45-88-3071	Washer	(1)
26	-----	Armature	(1)
27	02-04-1930	Ball Bearing	(1)
28	34-60-2493	Retaining Ring	(1)
29	06-82-2367	M3 x 38mm Pan Hd. ST T-10 Screw	(2)
30	06-82-2368	M3.5 x 16mm Pan Hd. ST T-10 Screw	(6)
31	-----	Housing Cover - Right Housing Halve	(1)
32	06-65-0465	Pin	(1)
33	06-82-2369	M3.5 x 22mm Pan Hd. ST T-10 Screw	(1)
34	40-50-1090	Spring	(1)
35	-----	Housing Support - Left Housing Halve	(1)
36	-----	Belt Clip	(1)
37	06-82-0130	6-32 x .275 Pan Hd. T-15 Screw	(1)
38	42-42-0018	Forward/Reverse Shuttle	(1)
46	42-06-0128	1/2" Square Friction Ring Anvil Assy.	(1)
48	14-46-0131	Impact Assembly	(1)
49	14-20-2861	Electronics Assembly	(1)
50	16-01-2860	Rotor Assembly	(1)
51	31-44-0069	Housing Assembly	(1)
52	45-24-2656	Speed Selector Assembly	(1)
53	42-70-2653	Belt Clip Assembly	(1)
54	12-20-2860	Service Nameplate	(1)
56	42-55-2860	Carrying Case	(1)
59	34-60-0011	Retaining Ring	(1)

FIG. LUBRICATION
Use Type 'J' Grease, No. 49-08-4220 (1 lb. can)
Service grease may not be compatible with grease used during manufacturing. 90-95% of the old grease must be removed prior to any new grease being added.



Detail shown with Switch and Fwd/Rev Shuttle removed to illustrate LED wires and Ground wire trapping and routing.

Detail shown with Switch, Fwd/Rev Shuttle, Impact Assembly and Gear Case removed to illustrate the Grounding Terminal placement over the Pin.

As an aid to reassembly, take note of wire routing and position in wire guides and traps while dismantling tool. Be careful and avoid pinching wires between handle halves when assembling.

Check for proper switch and shuttle functionality prior to securing handle halves._