



INSTRUCTION MANUAL
MANUEL D'INSTRUCTION
MANUAL DE INSTRUCCIONES

Pneumatic Framing Nailer Cloueuse Pneumatique Clavador neumático de marcos

AN923

AN943

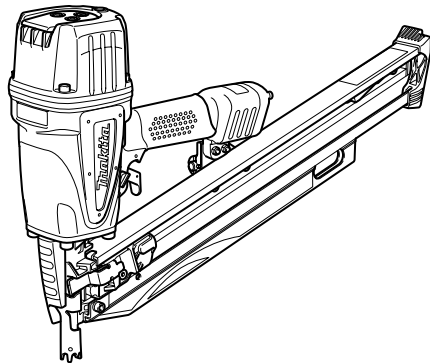

007004

⚠ WARNING:

For your personal safety, READ and UNDERSTAND before using.
SAVE THESE INSTRUCTIONS FOR FUTURE REFERENCE.

⚠ AVERTISSEMENT:

Pour votre propre sécurité, prière de lire attentivement avant l'utilisation.
GARDER CES INSTRUCTIONS POUR RÉFÉRENCE ULTÉRIEURE.

⚠ ADVERTENCIA:

Para su seguridad personal, LEA DETENIDAMENTE este manual antes de usar la herramienta.
GUARDE ESTAS INSTRUCCIONES PARA FUTURA REFERENCIA.

ENGLISH

SPECIFICATIONS

Model	AN923	AN943
Air pressure	4.5 - 8.5 kgf/cm ² G (65 - 120 PSIG)	
Nail length	50 mm (2") - 90 mm (3-1/2")	
Nail capacity	64 - 74 pcs.	60 - 84 pcs.
Min. hose diameter	8.5 mm (5/16")	
Dimensions (L X H X W)	559 mm X 347 mm X 109 mm (22" X 13-1/16" X 4-1/4")	455 mm X 365 mm X 109 mm (17-7/8" X 14-3/8" X 4-1/4")
Net weight	3.9 kg (8.7 lbs)	

- Due to our continuing programme of research and development, the specifications herein are subject to change without notice.
- Note: Specifications may differ from country to country.

IMPORTANT SAFETY INSTRUCTIONS

USB086-1

WARNING: WHEN USING THIS TOOL, BASIC SAFETY PRECAUTIONS SHOULD ALWAYS BE FOLLOWED TO REDUCE THE RISK OF PERSONAL INJURY, INCLUDING THE FOLLOWING:

READ ALL INSTRUCTIONS.

1. For personal safety and proper operation and maintenance of the tool, read this instruction manual carefully before using the tool.

2. Always wear safety glasses to protect your eyes from dust or nail injury. The safety glasses should conform with the requirements of ANSI Z87.1.

WARNING:

It is an employer's responsibility to enforce the use of safety eye protection equipment by the tool operators and by other persons in the immediate working area.

3. Wear hearing protection to protect your ears against exhaust noise and head protection. Also wear light but not loose clothing. Sleeves should be buttoned or rolled up. No necktie should be worn.

4. Rushing the job or forcing the tool is dangerous. Handle the tool carefully. Do not operate when under the influence of alcohol, drugs or the like.

5. General Tool Handling Guidelines:

(1) Always assume that the tool contains fasteners.

(2) Do not point the tool toward yourself or anyone whether it contains fasteners or not.

(3) Do not actuate the tool unless the tool is placed firmly against the workpiece.

(4) Respect the tool as a working implement.

(5) No horseplay.

(6) Do not hold or carry the tool with a finger on the trigger.

(7) Do not load the tool with fasteners when any one of the operating controls is activated.

(8) Do not operate the tool with any power source other than that specified in the tool operating/safety instructions.

6. An improperly functioning tool must not be used.

7. Sparks sometimes fly when the tool is used. Do not use the tool near volatile, flammable materials such as gasoline, thinner, paint, gas, adhesives, etc.; they will ignite and explode, causing serious injury.

8. The area should be sufficiently illuminated to assure safe operations. The area should be clear and litter-free. Be especially careful to maintain good footing and balance.

9. Only those involved in the work should be in the vicinity. Children especially must be kept away at all times.

10. There may be local regulations concerning noise which must be complied with by keeping noise levels within prescribed limits. In certain cases, shutters should be used to contain noise.

11. Do not play with the contact element: it prevents accidental discharge, so it must be kept on and not removed. Securing the trigger in the ON position is also very dangerous. Never attempt to fasten the trigger. Do not operate a tool if any

- portion of the tool operating controls is inoperable, disconnected, altered, or not working properly.
12. Operate the tool within the specified air pressure on the tool label for safety and longer tool life. Do not exceed the recommended max. operating pressure. The tool should not be connected to a source whose pressure potentially exceeds 14.0 kgf/cm²G (200 PSIG).
 13. Never use the tool with other than compressed air. If bottled gas (carbon dioxide, oxygen, nitrogen, hydrogen, air, etc.) or combustible gas (hydrogen, propane, acetylene, etc.) is used as a power source for this tool, the tool will explode and cause serious injury.
 14. Always check the tool for its overall condition and loose screws before operation. Tighten as required.
 15. Make sure all safety systems are in working order before operation. The tool must not operate if only the trigger is pulled or if only the contact element is pressed against the wood. It must work only when both actions are performed. Test for possible faulty operation with nails unloaded and the contact element in fully pulled position.
 16. Make sure that the trigger is locked when the change lever is set to the LOCK position.
 17. Check walls, ceilings, floors, roofing and the like carefully to avoid possible electrical shock, gas leakage, explosions, etc. caused by striking live wires, conduits or gas pipes.
 18. Use only nails specified in this manual. The use of any other nails may cause malfunction of the tool.
 19. Do not permit those uninstructed to use the tool.
 20. Make sure no one is nearby before nailing. Never attempt to nail from both the inside and outside at the same time. Nails may rip through and/or fly off, presenting a grave danger.
 21. Watch your footing and maintain your balance with the tool. Make sure there is no one below when working in high locations, and secure the air hose to prevent danger if there is sudden jerking or catching.
 22. On rooftops and other high locations, nail as you move forward. It is easy to lose your footing if you nail while inching backward. When nailing against perpendicular surface, nail from the top to the bottom. You can perform nailing operations with less fatigue by doing so.
 23. A nail will be bent or the tool can become jammed if you mistakenly nail on top of another nail or strike a knot in the wood. The nail may be thrown and hit someone, or the tool itself can react dangerously. Place the nails with care.
 24. Do not leave the loaded tool or the air compressor under pressure for a long time out in the sun.
- Be sure that dust, sand, chips and foreign matter will not enter the tool in the place where you leave it setting.
25. Do not point the ejection port at anyone in the vicinity. Keep hands and feet away from the ejection port area.
 26. When the air hose is connected, do not carry the tool with your finger on the trigger or hand it to someone in this condition. Accidental firing can be extremely dangerous.
 27. Handle the tool carefully, as there is high pressure inside the tool that can be dangerous if a crack is caused by rough handling (dropping or striking). Do not attempt to carve or engrave on the tool.
 28. Stop nailing operations immediately if you notice something wrong or out of the ordinary with the tool.
 29. Always disconnect the air hose and remove all of the nails:
 - (1) When unattended.
 - (2) Before performing any maintenance or repair.
 - (3) Before cleaning a jam.
 - (4) Before moving the tool to a new location.
 30. Perform cleaning and maintenance right after finishing the job. Keep the tool in tip-top condition. Lubricate moving parts to prevent rusting and minimize friction-related wear. Wipe off all dust from the parts.
 31. When not operating the tool, always lock the trigger by turning the change lever to the LOCK position.
 32. Do not modify tool without authorization from Makita.
 33. Do not attempt to keep the trigger or contact element depressed with tape or wire. Death or serious injury may occur.
 34. Always check contact element as instructed in this manual. Nails may be driven accidentally if the safety mechanism is not working correctly.
 35. Ask Makita's Authorized service centers for periodic inspection of the tool.
 36. To maintain product SAFETY and RELIABILITY, maintenance and repairs should be performed by Makita Authorized or Factory Service Centers, always using Makita replacement parts.

SAVE THESE INSTRUCTIONS



WARNING:

MISUSE or failure to follow the safety rules stated in this instruction manual may cause serious personal injury.

SYMBOLS

USD501-1

The followings show the symbols used for tool.

- Read and understand tool labels and manual.
- Operators and others in work area must wear safety glasses with side shields.
- Keep fingers away from trigger when not driving fasteners to avoid accidental firing.

INSTALLATION

Selecting compressor

005686

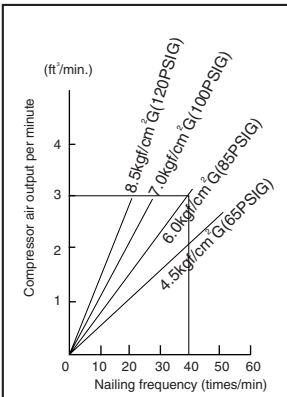

The air compressor must comply with the requirements of ANSI B19.3.

Select a compressor that has ample pressure and air output to assure cost-efficient operation. The graph shows the relation between nailing frequency, applicable pressure and compressor air output.

Thus, for example, if nailing takes place at a rate of approximately 40 times per minute at a compression of 6.0 kgf/cm²G (85 PSIG), a compressor with an air output over 3 ft³/minute is required.

Pressure regulators must be used to limit air pressure to the rated pressure of the tool where air supply pressure exceeds the tool's rated pressure. Failure to do so may result in serious injury to tool operator or persons in the vicinity.

Selecting air hose

004294

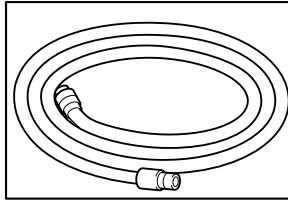

Use an air hose as large and as short as possible to assure continuous, efficient nailing operation. With an air pressure of 5.0 kgf/cm²G (70 PSIG), an air hose with an internal diameter of over 8.5 mm (5/16") and a length of less than 20 m (6.6 ft.) is recommended when the interval between each nailing is 0.5 seconds. Air supply hoses shall have a minimum working pressure rating of 10.7 kgf/cm²G (150 PSIG) or 150 percent of the maximum pressure produced in the system whichever is higher.

CAUTION:

- Low air output of the compressor, or a long or smaller diameter air hose in relation to the nailing frequency may cause a decrease in the driving capability of the tool.

Lubrication

004295

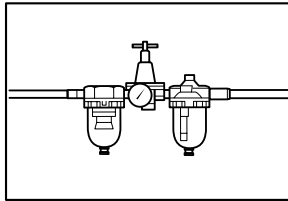

To insure maximum performance, install an air set (oiler, regulator, air filter) as close as possible to the tool. Adjust the oiler so that one drop of oil will be provided for every 30 nails.

When an air set is not used, oil the tool with pneumatic tool oil by placing 2 (two) or 3 (three) drops into the air fitting. This should be done before and after use. For proper lubrication, the tool must be fired a couple of times after pneumatic tool oil is introduced.

007005

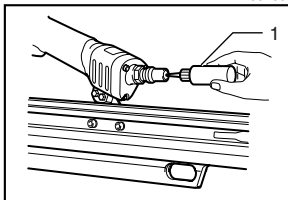

1. Pneumatic tool oil

FUNCTIONAL DESCRIPTION

⚠ CAUTION:

- Always lock the trigger and disconnect the hose before adjusting or checking function on the tool.

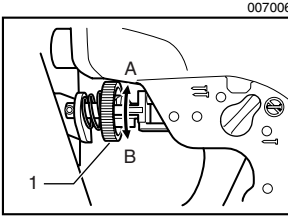

To adjust the depth of nailing, turn the adjuster. The depth of nailing is the deepest when the adjuster is turned fully in the A direction shown in the figure. It will become shallower as the adjuster is turned in the B direction. If nails cannot be driven deep enough even when the adjuster is turned fully in the A direction, increase the air pressure. If nails are driven too deep even when the adjuster is turned fully in the B direction, decrease the air pressure. Generally speaking, the tool service life will be longer when the tool is used with lower air pressure and the adjuster set to a lower depth of nail driving.

Hook

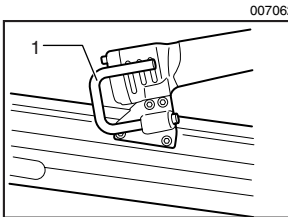

⚠ CAUTION:

- Always lock the trigger and disconnect the hose from the tool.
- Never hook the tool at high location or on potentially unstable surface.

The hook is convenient for hanging the tool temporarily.

To use the hook, simply lift up hook until it snaps into the open position.

When not in use, always lower hook until it snaps into the closed position.

ASSEMBLY

⚠ CAUTION:

- Always lock the trigger and disconnect the hose before carrying out any work on the tool.

Loading nailer

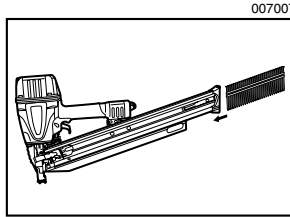

Select nails suitable for your work. Insert strip of nails into the magazine.

Pull the pusher lever to the rear to engage the pusher to the last nail.

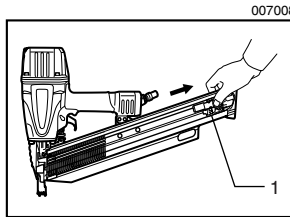

Unloading nailer

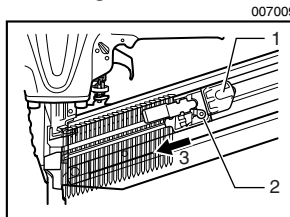

Pull the pusher lever to the rear. Return the pusher lever back while keeping the pusher depressed to disengage it from the strip of nails.

Depress the nail stopper and remove the strip of nails from the magazine.

007010

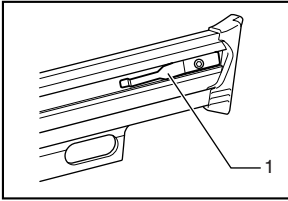

1. Nail stopper

Connecting air hose

007011

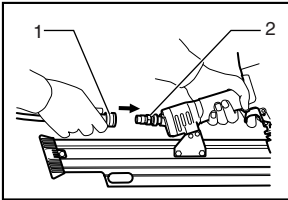

1. Air socket
2. Air fitting

Lock the trigger. Slip the air socket of the air hose onto the air fitting on the nailer. Be sure that the air socket locks firmly into position when installed onto the air fitting. A hose coupling must be installed on or near the tool in such a way that the pressure reservoir will discharge at the time the air supply coupling is disconnected.

OPERATION

⚠ CAUTION:

- Make sure all safety systems are in working order before operation.
- To drive a nail, you may place the contact element against the workpiece and pull the trigger, or

007012

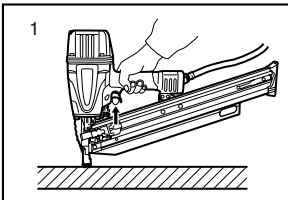

007013

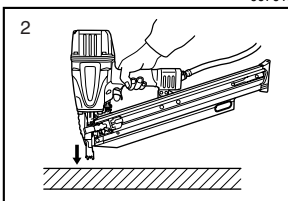



- Pull the trigger first and then place the contact element against the workpiece.
 - No. 1 method is for intermittent nailing, when you wish to drive a nail carefully and very accurately.
 - No. 2 method is for continuous nailing.

⚠ CAUTION:

- However when the tool is set to the "Intermittent Nailing" mode, WITH THE TRIGGER HELD IN A HALF-PULLED POSITION, an unexpected nailing could occur, if contact element is allowed to re-contact against the workpiece or the other surface under the influence of recoil.

In order to avoid this unexpected nailing, perform as follows;

- Do not place the contact element against the workpiece with excessive force.
- Pull the trigger fully and hold it on for 1-2 seconds after nailing.

- For No. 1 method, set the change lever to the  position.
- For No. 2 method, set the change lever to the  position.

After using the change lever to change the nailing method, always make sure that the change lever is properly set to the position for the desired nailing method.

007014

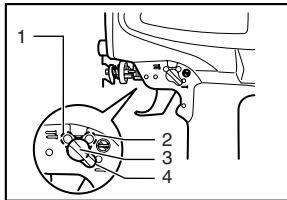

1. Continuous nailing
2. Trigger lock
3. Lock lever
4. Intermittent nailing

Anti dry fire mechanism

This tool is equipped with an anti dry fire mechanism. When there are a few nails remaining in the magazine, the contact arm will be locked in the undepressed position to prevent the tool from being activated. Load more nails to resume operation.

Jammed nailer

004308

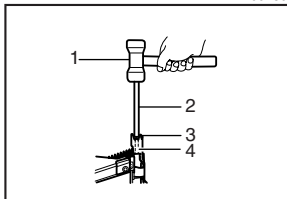

1. Hammer
2. Small rod
3. Ejection port
4. Driver

⚠ CAUTION:

- Always lock the trigger, disconnect the hose and remove the nails from the magazine before cleaning a jam.

When the nailer becomes jammed, do as follows:
Insert a small rod or the like into the ejection port and tap it with a hammer to retract the driver.

Use pliers to bend the jammed nail so that the nail head comes out of the slot in the driver guide. Then remove the jammed nail.

004309

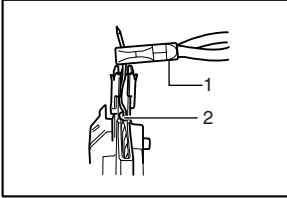

1. Pliers
2. Slot

Nails

004310

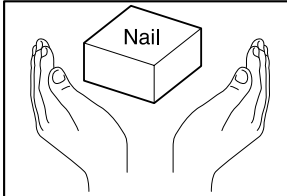

Handle nail coils and their box carefully. If the nail coils have been handled roughly, they may be out of shape or their connector breaks, causing poor nail feed.

Avoid storing nails in a very humid or hot place or place exposed to direct sunlight.

004311

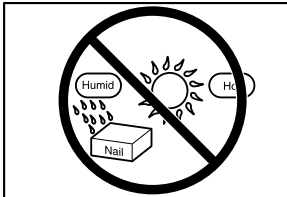

MAINTENANCE

⚠ CAUTION:

- Always disconnect the air hose from the tool before attempting to perform inspection or maintenance.

Maintenance of nailer

Always check the tool for its overall condition and loose screws before operation. Tighten as required.

007015

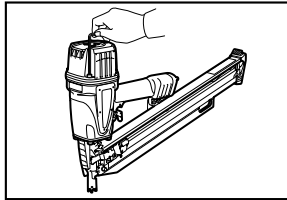

With tool disconnected, make daily inspection to assure free movement of the contact element and trigger. Do not use tool if the contact element or trigger sticks or binds.

007016

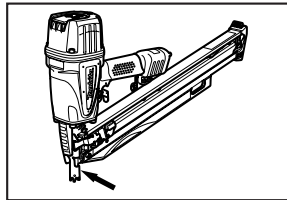

Make sure that the trigger is locked when the change lever is set to the  position.

007017

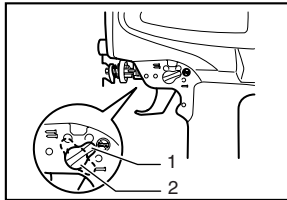

1. Trigger lock
2. Change lever

When the tool is not to be used for an extended period of time, lubricate the tool using pneumatic tool oil and store the tool in a safe place. Avoid exposure to direct sunlight and/or humid or hot environment.

007018

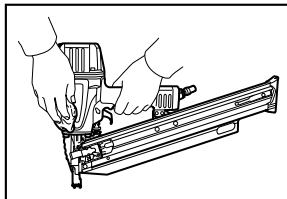

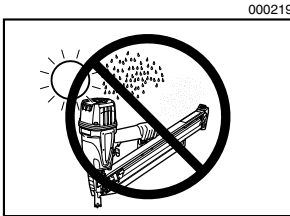

Maintenance of compressor, air set and air hose

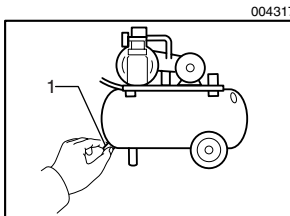

1. Drain cock

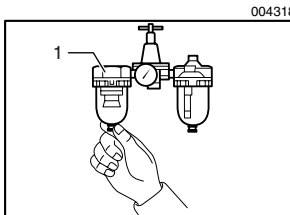

1. Air filter

After operation, always drain the compressor tank and the air filter. If moisture is allowed to enter the tool, it may result in poor performance and possible tool failure.

Check regularly to see if there is sufficient pneumatic oil in the oiler of the air set. Failure to maintain sufficient lubrication will cause O-rings to wear quickly.

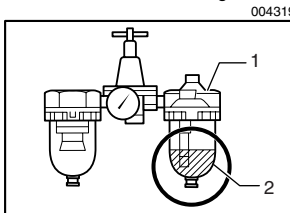

1. Oiler
2. Pneumatic oil

Keep the air hose away from heat (over 60°C, over 140°F), away from chemicals (thinner, strong acids or alkalis). Also, route the hose away from obstacles which it may become dangerously caught on during operation.

Hoses must also be directed away from sharp edges and areas which may lead to damage or abrasion to the hose.

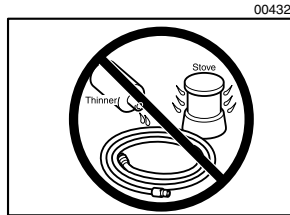

To maintain product SAFETY and RELIABILITY, repairs, any other maintenance or adjustment should be performed by Makita Authorized or Factory Service Centers, always using Makita replacement parts.

ACCESSORIES

⚠ CAUTION:

- These accessories or attachments are recommended for use with your Makita tool specified in this manual. The use of any other accessories or attachments might present a risk of injury to persons. Only use accessory or attachment for its stated purpose.

If you need any assistance for more details regarding these accessories, ask your local Makita Service Center.

- Nails
- Air hoses
- Safety goggles