

PIT+PLUS® SR - PREMIUM SIMPLEX SYSTEMS

APPLICATIONS

Collection of sewage, drainage or seepage water

FEATURES

- Roto-molded polyethylene basin 20" x 30" (51 cm x 76 cm)
- Radial rib design for extra strength
- Molded inlet hub
- Molded anti-torque stops
- 360° molded handle
- Integrated anti-floatation collar
- Optional alarm versions
- Pre-assembled
- Functional and aesthetic finish cover
- Pump access cover
- Recessed discharge and vent location
- Independent recessed switch module
- Monolithic molded basin top
- Switch cord grips and locators for directional control
- 4/10 hp or 1/2 hp sewage pump option available



SERIES SPECIFICATIONS

Item No.	Model No.	Vent	Discharge	Switch Type	Alarm	HP
509661	9SF2V2D	2"	2"	Float	-	4/10
509662	9SF2V2DA1	2"	2"	Float	Indoor	4/10
509663	9SF2V2DA3	2"	2"	Float	Indoor/Outdoor	4/10
509664	9SF2V3D	2"	3"	Float	-	4/10
509665	9SF2V3DA1	2"	3"	Float	Indoor	4/10
509666	9SF2V3DA3	2"	3"	Float	Indoor/Outdoor	4/10
509667	9SF3V2D	3"	2"	Float	-	4/10
509668	9SF3V2DA1	3"	2"	Float	Indoor	4/10
509669	9SF3V2DA3	3"	2"	Float	Indoor/Outdoor	4/10
509670	9SF3V3D	3"	3"	Float	-	4/10
509671	9SF3V3DA1	3"	3"	Float	Indoor	4/10
509672	9SF3V3DA3	3"	3"	Float	Indoor/Outdoor	4/10
509685	9SP2V2D	2"	2"	ECM	-	4/10
509686	9SP2V2DA1	2"	2"	ECM	Indoor	4/10

511661	10SF2V2D	2"	2"	Float	-	1/2
511662	10SF2V2DA1	2"	2"	Float	Indoor	1/2
511663	10SF2V2DA3	2"	2"	Float	Indoor/Outdoor	1/2
511664	10SF2V3D	2"	3"	Float	-	1/2
511665	10SF2V3DA1	2"	3"	Float	Indoor	1/2
511666	10SF2V3DA3	2"	3"	Float	Indoor/Outdoor	1/2
511667	10SF3V2D	3"	2"	Float	-	1/2
511668	10SF3V2DA1	3"	2"	Float	Indoor	1/2
511669	10SF3V2DA3	3"	2"	Float	Indoor/Outdoor	1/2
511670	10SF3V3D	3"	3"	Float	-	1/2
511671	10SF3V3DA1	3"	3"	Float	Indoor	1/2
511672	10SF3V3DA3	3"	3"	Float	Indoor/Outdoor	1/2
511685	10SP2V2D	2"	2"	ECM	-	1/2
511686	10SP2V2DA1	2"	2"	ECM	Indoor	1/2

Note: Check valve not included.



Basin Assemblies			
Item No.	Model No.	Vent	Discharge
513611	PPS2V2D	2"	2"
513612	PPS2V3D	2"	3"
513613	PPS3V3D	3"	3"
513614	PPS3V2D	3"	2"

Note: Pump and switch assembly not included.

PACKAGE SYSTEMS

PIT+PLUS® - PREMIUM SIMPLEX SYSTEMS

ENGINEERING DATA

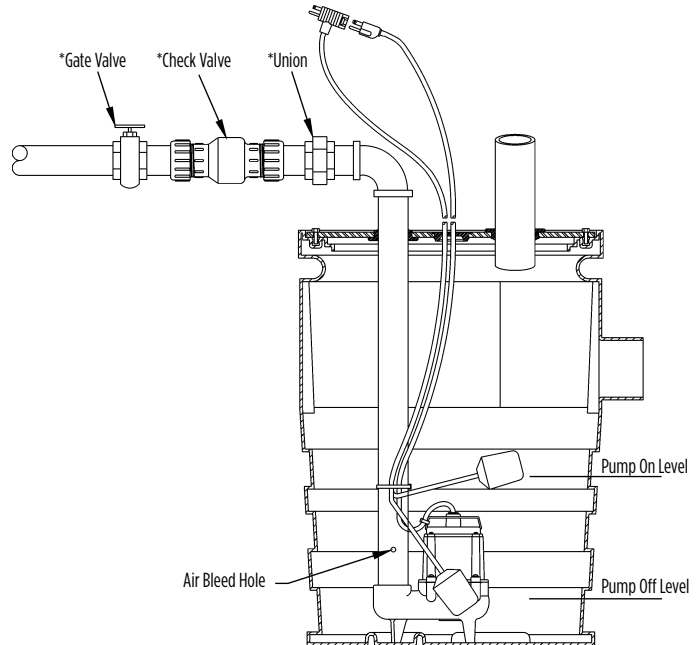
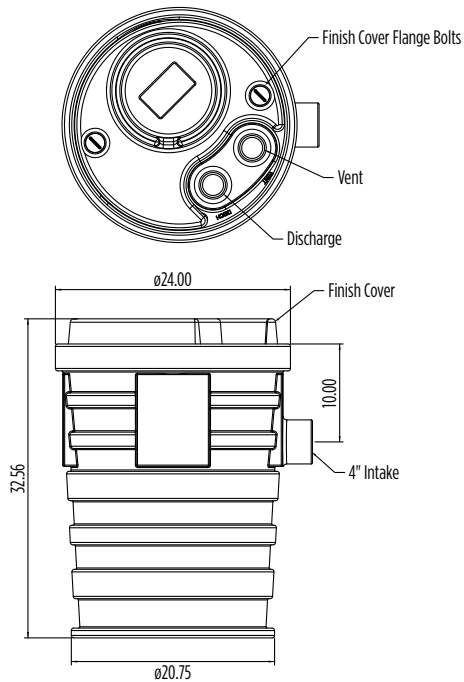

PERFORMANCE DATA

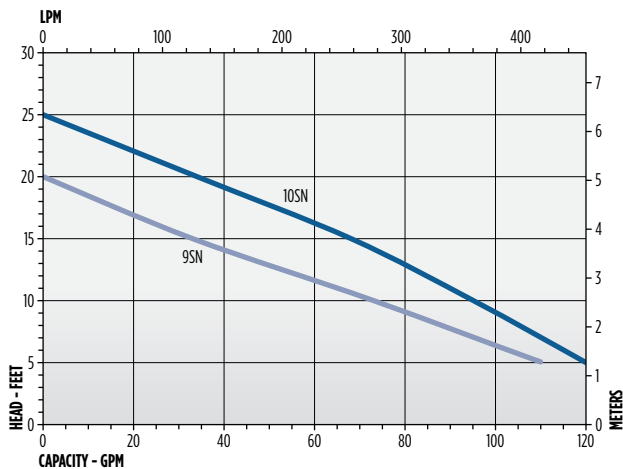

FLOAT AND ECM™ ASSEMBLIES



Float Assemblies		
Item No.	Model No.	Description
513631	PPSFNA	Senior Float Assy, No Alarm Hardware
513632	PPSFWA	Senior Float Assy, W/Alarm Hardware

ECM™ Assemblies		
Item No.	Model No.	Description
513635	PPSENA	Senior ECM Assy, No Alarm Hardware
513636	PPSEWA	Senior ECM Assy, W/Alarm Hardware