

FIG. 1

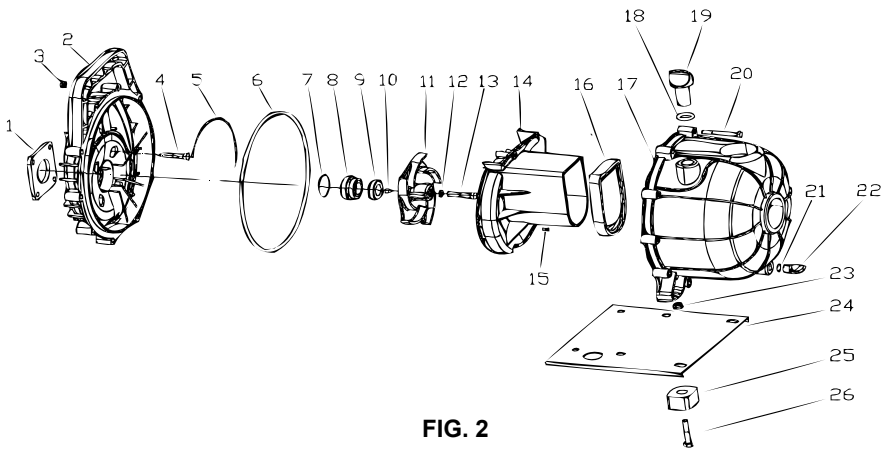

FIG. 2

Replacement Parts				
Group	Description	Components	Part Number	UPC Code
A	Bracket Kit	1,2,3,4	617150	0 10121 14421 7
B	Seal Kit	5,6,7,8,9	617151	0 10121 14422 4
C	Impeller Kit	10,11,12,13	617152	0 10121 14423 1
D	Volute	14,15	617153	0 10121 14424 8
E	Check Valve	16	617154	0 10121 14425 5
F	Plug Kit	18,19,21,22	617155	0 10121 14426 2
G	Casing Kit	17,20	617156	0 10121 14427 9
H	Base Kit	23,24,25,26	617157	0 10121 14428 6