

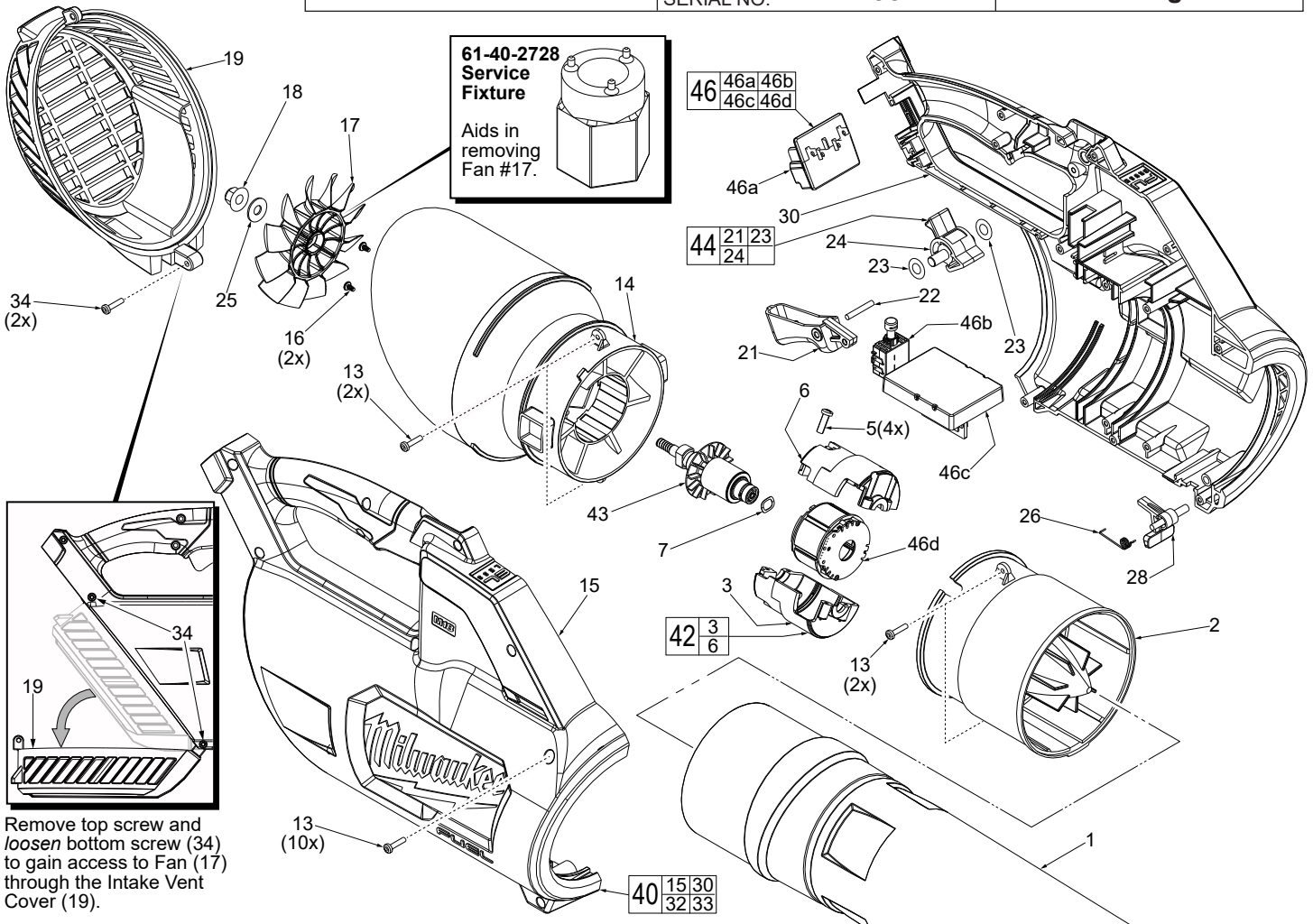

SERVICE PARTS LIST

BULLETIN NO.
54-05-2700

SPECIFY CATALOG NO. AND SERIAL NO. WHEN ORDERING PARTS		REVISED BULLETIN	DATE
M18™ FUEL™ BLOWER			Mar. 2018
CATALOG NO. 2728-20	STARTING SERIAL NO. H33A	WIRING INSTRUCTION See Page 2	



Remove top screw and loosen bottom screw (34) to gain access to Fan (17) through the Intake Vent Cover (19).

FIG.	PART NO.	DESCRIPTION OF PART	NO. REQ.
1	43-24-0400	Exhaust Tube	1
2	43-72-0277	Cone Section	1
3	-----	Motor Insulator-Right	1
5	06-82-6350	M3 x 16 Pan Hd. ST T-10 Screw	4
6	-----	Motor Insulator-Left	1
7	45-88-0167	Wave Washer	1
13	05-88-1200	M4 x 18 Pan Hd. ST T-20 Screw	14
14	22-84-0205	Static Fan	1
15	-----	Housing Cover - Right Housing Halve	1
16	06-82-3835	#6-19 PT T-15 Screw	2
17	22-84-0006	Fan	1
18	05-55-0033	M7 x 1 Hex Nut	1
19	31-15-0044	Intake Vent Cover	1
21	-----	Trigger	1
22	06-65-0061	Steel Pin	1
23	34-40-0054	O-Ring	2
24	-----	Speed Dial	1
25	45-88-0064	Washer	1
26	40-50-0064	Spring	1
28	44-20-0076	Nozzle Lock	1
30	-----	Housing Support - Left Housing Halve	1
32	10-20-1042	Caution Label (Not Shown)	1
33	12-20-0087	Service Nameplate (Not Shown)	1
34	05-88-1650	M4 x 25mm Pan Hd. ST T-20 Screw	2
40	31-44-2728	Housing Kit	1
42	23-16-0110	Motor Insulator Kit	1
43	16-01-0065	Rotor Assembly	1
44	43-98-0285	Trigger / Speed Dial Kit	1
46	14-20-2728	Electronics Assembly	1

EXAMPLE:
Component Parts (Small #)
Are Included When Ordering
The Assembly (Large #).

FIG.	PART NO.	DESCRIPTION OF PART	NO. REQ.
46a	-----	Battery Terminal Block Assembly	1
46b	-----	Switch	1
46c	-----	PCBA/Hall Board	1
46d	-----	Stator Assembly	1
61-40-2728	-----	Service Fixture (Shown in detail above) An aid for removing fan #17	1

SCREW TORQUE SPECIFICATIONS				
FIG.	PART NO.	WHERE USED	SEAT TORQUE	
			(KG/CM)	(IN/LBS)
13	05-88-1200	Housing, Static Fan	8-12	6.9-10.4
5	06-82-6350	Motor Insulator	4-8	3.4-6.9
16	06-82-3835	Static Fan	3-6	2.6-5.2
18	05-55-0033	Fan	17-20	14.7-17.3
34	05-88-1650	Intake Vent Cover	8-12	6.9-10.4

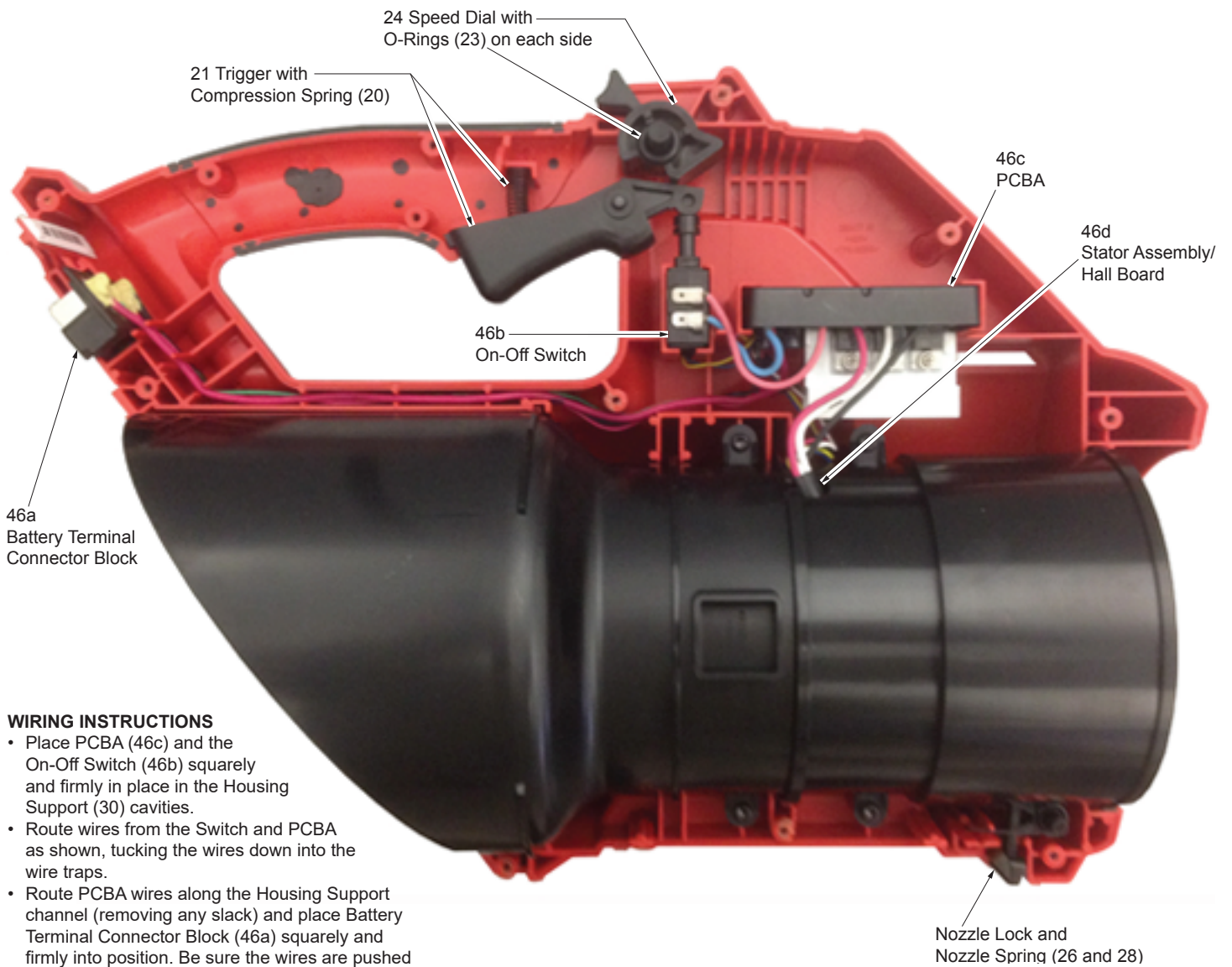

WIRING INSTRUCTIONS

- Place PCBA (46c) and the On-Off Switch (46b) squarely and firmly in place in the Housing Support (30) cavities.
- Route wires from the Switch and PCBA as shown, tucking the wires down into the wire traps.
- Route PCBA wires along the Housing Support channel (removing any slack) and place Battery Terminal Connector Block (46a) squarely and firmly into position. Be sure the wires are pushed down into the wire traps.
- Note routing and placement of the HV ground wire. HV terminal to be placed as shown at rear of Motor Insulator halves.
- Be sure the Trigger (21), Spring (20), Speed Dial with O-Rings (24 and 23) are properly in place.
- Be sure the Nozzle Lock and Nozzle Lock Spring (26 and 28) are in place.
- Place Intake Vent Cover (19) onto Support
- Housing and carefully place Housing Cover (15) onto the Housing Support (30).
- Secure the Intake Vent Cover (19) between the housing halves using the two longer screws (34)
- Secure the housing halves together using 10 of the shorter screws (13).
- Check for the proper functionality of the Switch Trigger (21) and Speed Dial (24).
- Insert battery pack and check tool for proper operation.

