



SERVICE PARTS

BULLETIN NO.
54-49-8400

SPECIFY CATALOG NO. AND SERIAL NO. WHEN ORDERING PARTS		REVISED BULLETIN	DATE
PACKOUT™ Rolling Tool Box Assembly			Aug. 2019
CATALOG NO. 48-22-8426	SERIAL NUMBER	WIRING INSTRUCTION	

48-22-8426 Includes:

48-22-8425	PACKOUT™ Large Tool Box Assembly
48-22-8424	PACKOUT™ Medium Tool Box Assembly
48-22-8430	PACKOUT™ Organizer Assembly
48-22-8435	PACKOUT™ Compact Organizer Assembly
48-22-8310	PACKOUT™ Small 10" Storage Tote
48-22-8315	PACKOUT™ Medium 15" Storage Tote
48-22-8320	PACKOUT™ Large 20" Storage Tote

EXAMPLE:
Component Parts (Small #) Are Included When Ordering The Assembly (Large #).

FIG.	PART NO.	DESCRIPTION OF PART	NO. REQ.
1	43-62-8400T	Retractable Handle Grip Service Kit	(1)
2	-----	Screw	(2)
3	43-62-8400	Retractable Handle Service Assembly	(1)
4	-----	Screw	(2)
5	43-62-8426	Side Handle Service Kit (Contains 2 Side Handles and 4 Pins)	(1)
6	-----	Pin	(4)
7	45-94-8426	Wheel Service Kit (Contains 2 Wheels and 2 Locking Hex Nuts)	(1)
8	-----	Locking Hex Nut	(2)
9	44-20-8400	Latch Service Assembly (Set of 2)	(1)
10	31-01-8400	Storage Tray	(1)
11	43-44-8400	Lid Gasket (Not Shown)	(1)
12	42-12-8426	Axle Service Kit (Contains 1 Axle and 2 Locking Hex Nuts)	(1)

***See page 6 thru 9 for Additional Storage Products:**

48-22-8431	PACKOUT™ S-Organizer Assembly
48-22-8436	PACKOUT™ S-Organizer Compact Assembly
48-22-8450	PACKOUT™ Tool Box Assembly
48-22-8321	PACKOUT™ Medium 15" Tool Bag
48-22-8322	PACKOUT™ Large 20" Tool Bag
48-22-8300	PACKOUT™ Tech Bag
48-22-8301	PACKOUT™ Jobsite Backpack
48-22-8302	PACKOUT™ Jobsite Cooler
48-22-8410	PACKOUT™ Flat Dolly

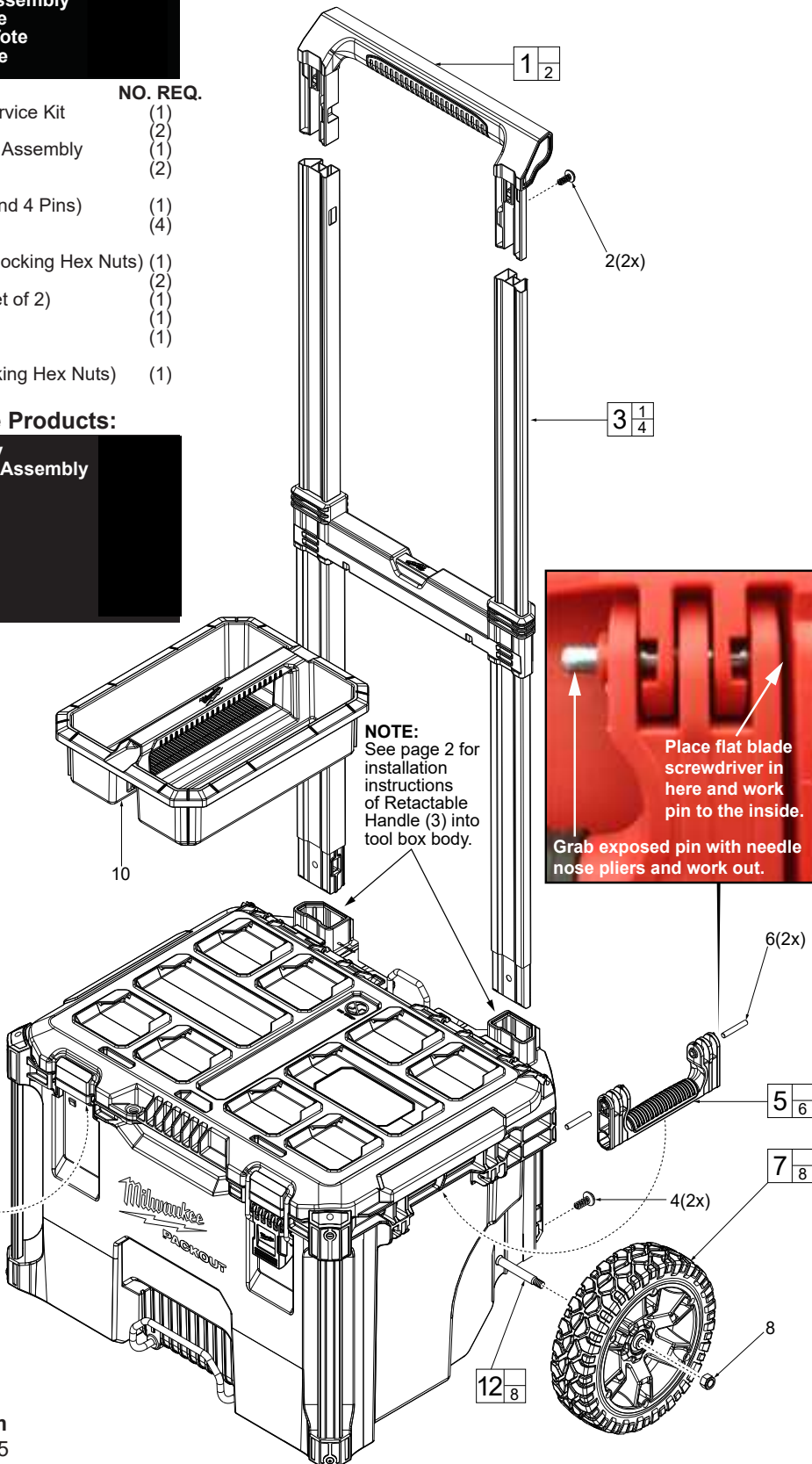

As an aid to removing a damaged Latch Assembly (9), use two large flat blade screwdrivers. Push blades between parts as shown. Twist both screwdrivers at same time to force the blades into opening and work the latch assembly over the two locking tabs.

To install a new latch assembly, position entire latch assembly over locking tabs with the two top lugs partially inserted in 'catch cavity' of main housing. Engage latch bar onto lid and gently press latch lever to slide assembly over two locking tabs and into place.

This removal and installation process will be the same where other service latches are offered in this system.

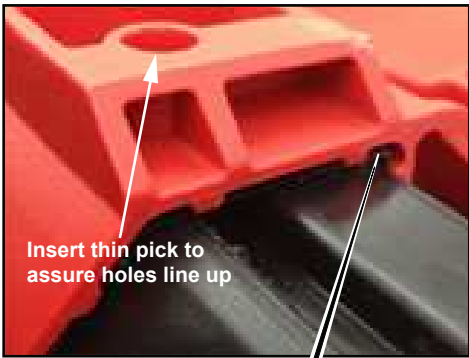

As an aid to installation, collapse the Retractable Handle Assembly (3).

Properly orient the assembly and insert both sides into tool box channels.

Holes of Retractable Handle Assembly (3) must line up with holes on the back of tool box body prior to securing with screws (4).

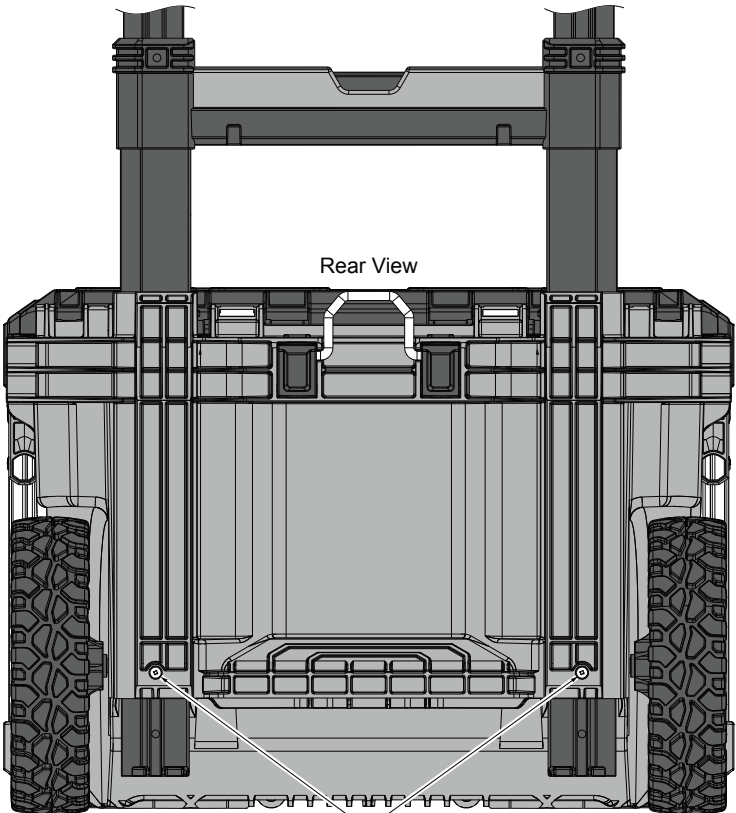

48-22-8300 PACKOUT™ Tech Bag



48-22-8301 PACKOUT™ Jobsite Backpack



48-22-8302 PACKOUT™ Jobsite Cooler



FIG.	PART NO.	DESCRIPTION OF PART	NO. REQ.
1	45-56-8300	Shoulder Strap (For Cooler & Tech Bag)	(1)
2	44-20-0305	Locker System	(1)

SEE PAGE 5 FOR INSTRUCTIONS ON REMOVING AND INSTALLING BOTH LOCKER SYSTEMS

