



# OWNER'S MANUAL

FOR USE WITH L.P. GAS (LIQUIFIED PETROLEUM GAS)  
IN CANADA - PROPANE GAS



ANSI Z21.89b-2006/CSA 1.18b-2006

## CONTENTS

SAFETY..... 2

INSTALLATION ..... 3

L.P. GAS CYLINDER..... 4

OPD EQUIPPED CYLINDER..... 5

HOSE & REGULATOR..... 5

LEAK TESTING ..... 6

VENTURI TUBE..... 6

LIGHTING ..... 7

OPERATION ..... 8

COOKING TECHNIQUES..... 9

RECIPES..... 10

MAINTENANCE..... 12

TROUBLE SHOOTING..... 13

WARRANTY..... 14

Please record your model and serial number here.

\_\_\_\_\_ Model number

\_\_\_\_\_ Serial number

\_\_\_\_\_ Date of purchase



**THIS INSTRUCTION MANUAL CONTAINS IMPORTANT INFORMATION NECESSARY FOR THE PROPER ASSEMBLY AND SAFE USE OF THE APPLIANCE. READ AND FOLLOW ALL WARNINGS AND INSTRUCTIONS BEFORE ASSEMBLING AND USING THE APPLIANCE. FOLLOW ALL WARNINGS AND INSTRUCTIONS WHEN USING THE APPLIANCE**

**KEEP THIS MANUAL FOR FUTURE REFERENCE.**

**IF INSTRUCTIONS OR PARTS ARE MISSING CONTACT ONWARD MANUFACTURING AT 1-800-474-5776.**

1-800-265-2150  
[info@omcbbq.com](mailto:info@omcbbq.com)

*Onward*  
 SINCE 1906  
 MANUFACTURING COMPANY LIMITED  
 585 KUMPF DRIVE  
 WATERLOO, ONTARIO, CANADA  
 N2V 1K3

31845  
01/07

# SAFETY

Your new Grillpro gas smoker is a safe, convenient appliance when assembled and used properly. However, as with all gas-fired products, certain safeguards must be observed. **Failure to follow these safeguards may result in damage or injury.** If you have questions concerning assembly or operation, consult your dealer, gas appliance serviceman, your gas company or our direct customer service line at 800-265-2150.

 <b>DANGER: FOR YOUR SAFETY</b>
<ul style="list-style-type: none"><li>• <b>If you smell gas:</b></li></ul> <ol style="list-style-type: none"><li><b>1. Shut off gas to the appliance.</b></li><li><b>2. Extinguish any open flame.</b></li><li><b>3. Open lid.</b></li><li><b>4. If odor continues, immediately call your gas supplier or your fire department.</b></li></ol>
<b>Failure to follow these instructions could result in fire or explosion, which could cause property damage, personal injury or death</b>

 <b>DANGER: FOR YOUR SAFETY</b>
<ol style="list-style-type: none"><li><b>1. Never operate this appliance unattended.</b></li><li><b>2. Never operate this appliance within 10ft (3m) of any structure, combustible material or other gas cylinder.</b></li><li><b>3. Never operate this appliance with in 25ft (7.5m) of any flammable liquid.</b></li><li><b>4. If fire should occur, keep away from the appliance and immediately call your fire department. Do not attempt to extinguish an oil or grease fire with water.</b></li></ol>
<b>Failure to follow these instructions could result in fire, explosion or burn hazard, which could cause property damage, personal injury or death</b>

## ELECTRICAL CAUTION

1. If any accessory is used on this appliance that requires an external electrical power source, the accessory when installed must be electrically grounded in accordance with local codes. In the absence of local codes, the following standards apply:

**(U.S.A.) ANSI/NFPA No. 70-Latest Edition  
and**

**(CANADA) CSA C22.1 Canadian Electrical Code**

2. Do not cut or remove the grounding prong from the plug.
3. Keep the electrical supply cord and fuel supply hose away from any heated surface.

## WARNING

Fuels used in gas or oil-fired appliances, and the products of combustion of such fuels, contain chemicals known to the State of California to cause cancer, birth defects or other reproductive harm.

"This warning is issued pursuant to California Health and Safety Code Sec. 25249.6"

# INSTALLATION

1. In the U.S.A., this appliance must be installed in accordance with the local code and the relevant national code.

**ANSI Z223.1/NFPA 54-National Fuel Gas Code,  
ANSI/NFPA 58-Storage and Handling of Liquefied  
Petroleum Gases**

**and Latest Local Codes where Applicable**

In Canada, this appliance must be installed in accordance with the local code and the relevant CGA standards:

**CAN/CSA-B149.1 LP Gas/Propane Installation Code,  
CAN/CSA B149.2-Propane Storage and Handling  
and Latest Local Codes where Applicable**

2. The appliance must be located away from combustible surfaces by at least 3m/10ft from each side, and 3m/10ft from the rear.

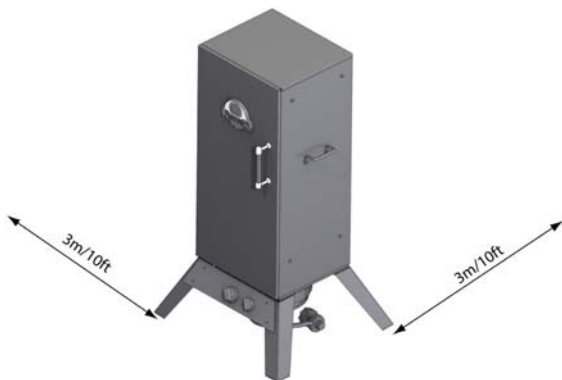

3. Do **not** operate this appliance under any overhead roof construction or foliage.
4. This appliance is for **OUTDOOR USE ONLY, DO NOT** operate in garage, shed, balcony or other such enclosed areas.
5. **DO NOT** restrict the flow of air to the appliance.
6. Keep the area surrounding the appliance free of combustible materials, gasoline, and all flammable liquids and vapours.
7. This appliance is not intended to be installed in, or on, recreational vehicles and/or boats.
8. Do not leave the appliance unattended. Keep children and pets away from the appliance at all times.
9. The use of alcohol, prescription or non- prescription drugs may impair the consumer's ability to properly assemble or safely operate the appliance.
10. This appliance is not intended for and should never be used as a heater.
11. The appliance will be hot during and after use. Protect yourself with insulated oven gloves or mitts.

12. It is important when installing the burner to make sure it is correctly centered and aligned with the orifice of the valve. This is critical to the safe operation of the appliance.

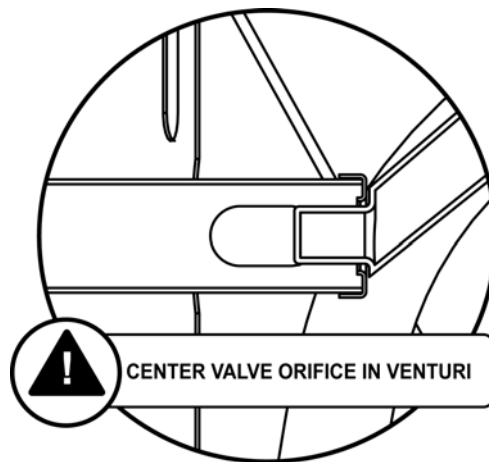
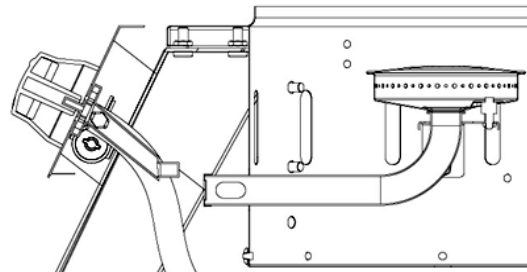

## LP GAS CYLINDER PLACEMENT

12. Cylinders must be installed according to assembly instructions. Do not store a spare cylinder under or near this appliance.
13. The regulator hose when extended and attached to the tank may become a tripping hazard. Care should be taken when walking around the appliance.

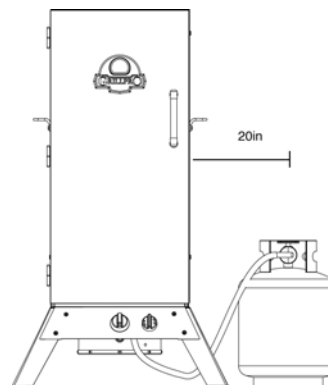

# LP GAS CYLINDER

## QCC<sup>®</sup>-1 QUICK CLOSING COUPLING

All models are designed to be used with an LP gas cylinder equipped with the new QCC<sup>®</sup>-1 Quick Closing Coupling system.

The QCC<sup>®</sup>-1 system incorporates new safety features required by the American National Standards Institute (ANSI) and the Canadian Standards Steering Committee.

- Gas will not flow until a positive connection has been made.
- A thermal element will shut off the flow of gas between 240° and 300° F.
- When activated, a Flow Limiting Device will limit the flow of gas to 10 cubic feet per hour.

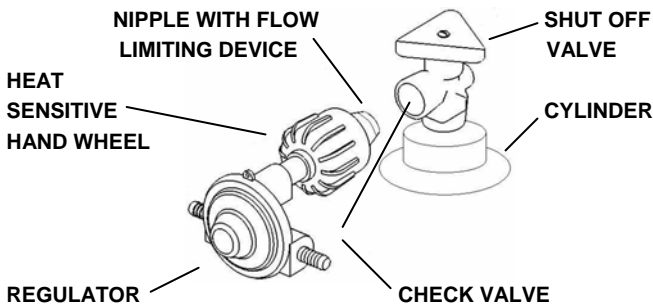

**The LP Gas Cylinder is not included with the Gas Smoker.** Be sure to purchase one with the QCC<sup>®</sup> valve. This valve is recognized by the external threads on the inlet port of the valve. QCC<sup>®</sup> equipped cylinders are available from your Gas Grill Dealer.

**Any attempt to connect the regulator, by use of adapters or any other means, to any other valve could result in damage, fire or injury and may negate the important safety features designed into the QCC<sup>®</sup>-1 system.**

### SPECIFICATION:

1. Constructed and marked in accordance with the *Specifications for LP Gas Cylinders* of the U.S. Department of Transportation (D.O.T.) or the National Standard of Canada, *CAN/CSA-B339, Cylinders, Spheres and Tubes for Transportation of Dangerous Goods; and Commission*, as applicable; and
2. The LP gas cylinder used for this appliance must not have a capacity larger than 20 lb. (9 kg).  
Approximately 18" (46cm) high  
12" (31cm) diameter
3. All LP gas cylinders used with this appliance should be inspected at every filling and re qualified by a licensed service outlet at the expiry date (10 years), in accordance with the DOT (USA) and CTC (Canada) codes for LP Gas Cylinders.
4. All LP gas cylinders used with this appliance must be provided with a shutoff valve terminating in a cylinder valve outlet No. 510, specified in the Standard for Compressed Gas Cylinder Valve Outlet and Inlet Connection (USA) ANSI/CGA-V-1-1977 (Canada) CSA B96.

The cylinder supply system must be arranged for vapor withdrawal.

The cylinder must include a collar to protect the cylinder valve.

The cylinder must be installed as per assembly instructions.

Never fill the cylinder beyond 80% full. A fire causing death or serious injury may occur.

The cylinder valve must include a safety relief device having direct communication with the vapor space of the cylinder.

### HANDLING:

1. Government regulations prohibit shipping full LP gas cylinders. You must take your new cylinder to a LP gas dealer for filling.
2. A filled LP gas cylinder is under very high pressure. Always handle carefully and transport in the **upright** position. Protect the valve from accidental damage.
3. Do not tip the LP gas cylinder while connecting it to the regulator. Fasten the cylinder securely during transport, use and storage.
4. If the cylinder is tipped after it is connected to the regulator, shut off the gas, disconnect the regulator and have it checked before using again.

### STORAGE:

1. Store the LP gas cylinder outdoors in a well ventilated place.
2. Do not store the LP gas cylinder in direct sunlight, near a source of heat or combustion.
3. If you intend to store the grill indoors, disconnect and remove the LP gas cylinder first. Disconnected cylinders must have a dust cap installed and must not be stored in a building, garage or any other enclosed area.
4. Keep out of the reach of children.
5. When the LP gas cylinder is connected to the gas grill, the gas grill and LP gas cylinder must be stored outside in a well ventilated place.
6. Place dust cap on cylinder valve outlet whenever the cylinder is not in use. Only install the type of dust cap on the cylinder valve outlet that is provided with the cylinder valve. Other types of caps or plugs may result in leakage of propane.

### OPERATION:

1. Never connect your gas grill to an LP gas cylinder without the regulator provided, and **NEVER TO AN UNREGULATED LP GAS SUPPLY**. The gas regulator supplied with the appliance must be used.
2. **Always** leak test the LP gas cylinder to regulator connection when connecting the LP gas cylinder to the appliance. See "Leak Testing".
3. **Do not** operate appliance if the smell of LP gas is present. Extinguish all flame and determine source of LP gas before proceeding. **Do not** ignite the appliance until the LP gas leak has been found and sealed.
4. **Always** shut off LP gas cylinder valve when the appliance is not in use

# OPD EQUIPPED CYLINDER

# HOSE & REGULATOR

## OVERFILL PREVENTION DEVICE

Effective January 1, 1998, the standard for outdoor gas appliances, ANSI Z21.58/CAN/CGA-1.6, requires that appliances are to be used with cylinders equipped with an Overfill Prevention Device (OPD).

The OPD is designed to reduce the potential for the overfilling of propane cylinders, thus reducing the possibility of relief valve discharges of raw propane. **The new OPD causes a slower purge/fill operation.** Some consumers have been advised by filling stations that these cylinders are "defective". **This is not a defect.** Some propane filling stations may not be aware of this new device and its effect on the purge/fill operation.

New OPDs coming onto the market have new technology that allows for much greater BTU outputs which will decrease the amount of time it takes to purge a cylinder.

## IDENTIFICATION

To identify these cylinders, the new OPD hand wheel has been standardized to the shape shown.

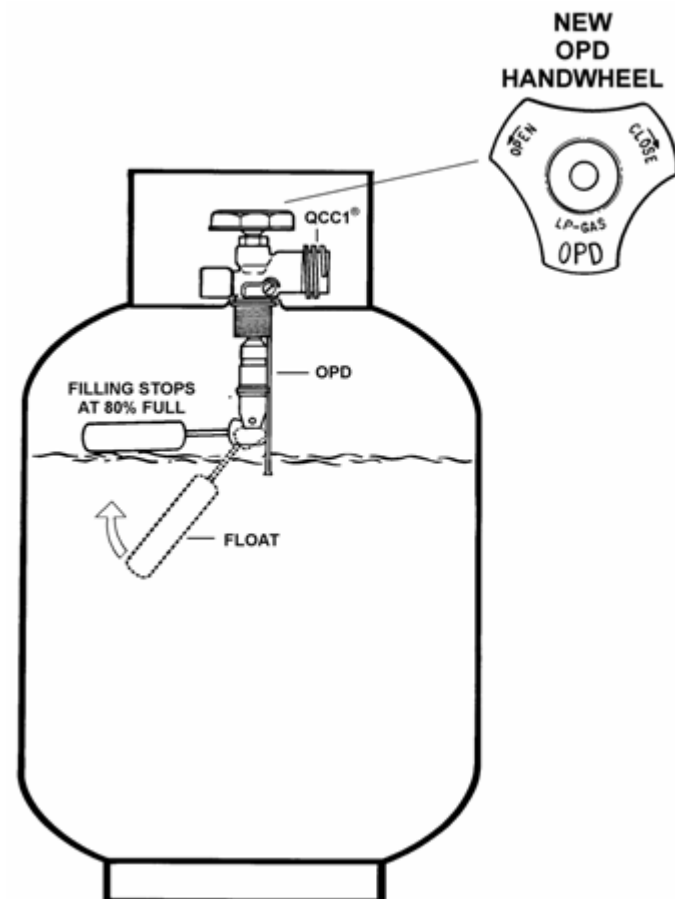

All models are equipped with a hose and regulator with a QCC<sup>®</sup>-1 Quick Closing Coupling.

1. The QCC<sup>®</sup> coupling contains a magnetic Flow Limiting Device which will limit the flow of gas should there be a leak between the regulator and the appliance valve. This device will activate if the cylinder valve is opened while the appliance valves are open. **Be sure the appliance valves are off before the cylinder valve is opened to prevent accidental activation.**
2. The QCC<sup>®</sup> coupling incorporates a heat sensitive hand wheel that will cause the back check module in the QCC<sup>®</sup> cylinder valve to close when exposed to temperatures between 240° and 300°F. Should this occur, do not attempt to reconnect the nut. Remove hose/regulator assembly and replace with a new one.
3. The pressure regulator is set at 11 inches WC (water column) and is for use with LP gas only. The hose and hose couplings comply with CGA Standard CAN 1.83. No modifications or substitutions should be attempted.
4. Protect the hose from dripping grease and **do not allow the hose to touch any hot surface, including the base casting of the Smoker.**
5. Inspect seal in the QCC<sup>®</sup> cylinder valve when replacing LP gas cylinder or once per year whichever is more frequent. Replace seal if there is any indication of cracks, creases, or abrasion.
6. Inspect hose before each use of the smoker. If the hose is cracked, cut, abraded or damaged in any way, the appliance must **not** be operated.
7. For repair or replacement of hose/regulator assembly, contact customer service at 1-800-265-2150 or [INFO@OMCBBQ.com](mailto:INFO@OMCBBQ.com).

## CONNECTION

1. Be sure cylinder valve and appliance valves are "off".

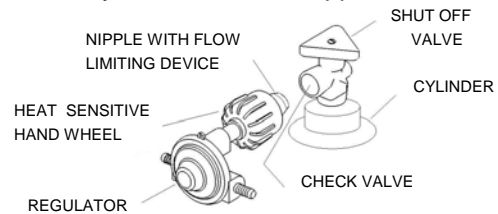

2. Place full LP gas cylinder in LP tank well and secure base as per assembly instructions.
3. Center the nipple in the cylinder valve and hold in place. Using other hand, turn the hand wheel clockwise until there is a positive stop. **Do not use tools. Hand tighten only. When making the connection, hold the regulator in a straight line with the cylinder valve, so as not to cross thread the connection.**
4. Leak test connections. See "Leak Testing".
5. Refer to lighting instructions. **To avoid activating the Flow Limiting Device when lighting, open cylinder valve slowly with the appliance valves off.** If the Flow Limiting Device is accidentally activated, turn off cylinder valve and appliance valves, wait 10 seconds to allow the device to reset, open cylinder valve slowly, then open the appliance valve.

# LEAK TESTING

All factory-made connections have been thoroughly tested for gas leaks. However, shipping and handling may have loosened a gas fitting.

## AS A SAFETY PRECAUTION:

**TEST ALL FITTINGS FOR LEAKS BEFORE USING YOUR GAS SMOKER.**

**TEST THE CYLINDER VALVE FOR LEAKS EACH TIME THE CYLINDER IS FILLED.**

**TEST FOR LEAKS EVERY TIME YOU CONNECT A GAS FITTING.**

**DO NOT SMOKE!**

**NEVER TEST FOR LEAKS WITH A LIGHTED MATCH OR OPEN FLAME.**

**TEST FOR LEAKS OUTDOORS.**

## TO TEST FOR LEAKS:

1. Extinguish any open flame or cigarettes in the area.
2. Be sure that cylinder valve and appliance valves are "off".
3. Connect LP gas cylinder. See "Hose and Regulator".
4. Prepare a soap solution of one part water, one part liquid detergent.
5. With a full gas cylinder, open cylinder slowly.
6. Brush the soap solution on each connection.
7. A leak is identified by a flow of bubbles from the area of the leak.



8. If a leak is detected, close the gas cylinder "shut-off" valve, tighten the connection and retest (Step 5).
9. If the leak persists, contact your smoker dealer for assistance. Do not attempt to operate appliance if a leak is present.

# VENTURI TUBE

- **KEEP VENTURI TUBE CLEAN.**
- **Blockages caused by spiders insects and nests can cause a flashback fire.**

Although the smoker might still light, the backed up gas might also ignite and cause a fire around the venturi tube at the control panel.

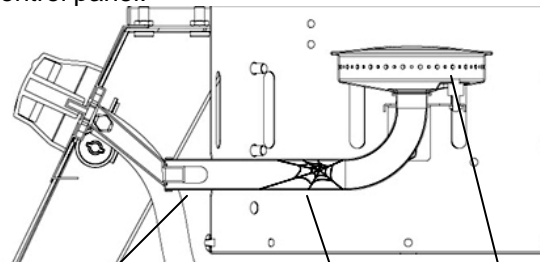

VENTURI TUBE SPIDER WEB BURNER

- **If a flashback fire occurs, turn off gas at the source immediately**

**Inspect and clean the venturi tube if any of the following symptoms occur:**

1. You smell gas.
2. Your smoker does not reach temperature.
3. Your smoker heats unevenly.
4. The burner makes popping noises.

## Inspecting & Cleaning Venturi Tube

1. Turn off gas at the source, the gas cylinder.
2. When smoker is cool, remove control panel fasteners, and lift the control panel free of legs and venturi tube.
3. Clean the venturi tube with a pipe cleaner or venturi cleaning tool (Accessory #77310).

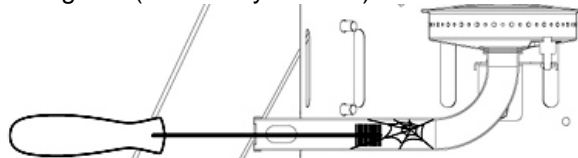

4. Lower the control panel into position, making sure that the venturi tube is correctly aligned and fitted on the orifice. It is important that the burner is correctly centered and aligned with the orifice of the valve.

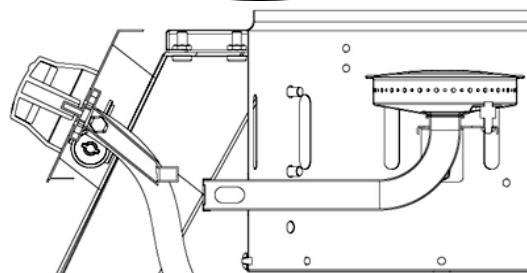
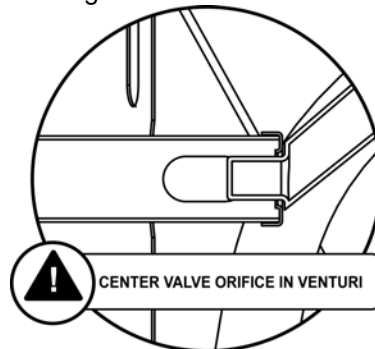

5. Secure control panel with fasteners.

# LIGHTING

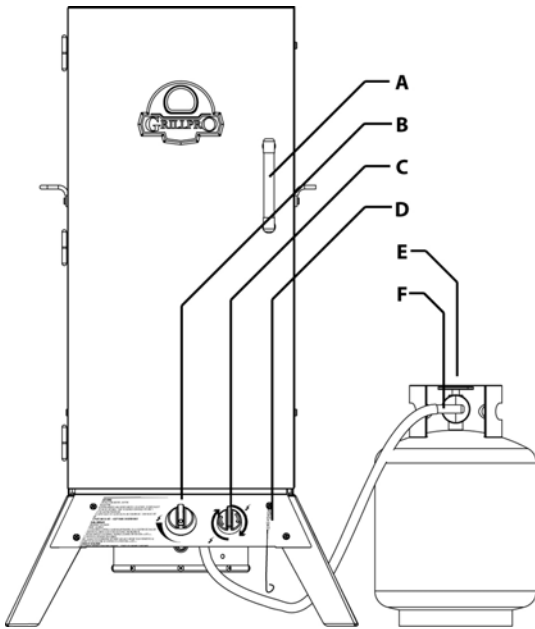

- A. HANDLE
- B. BURNER CONTROL
- C. IGNITER
- D. MANUAL LIGHTING MATCH HOLDER
- E. REGULATOR
- F. CYLINDER VALVE

1. The appliance must be assembled as per the assembly instructions.
2. Check that your gas cylinder is full and properly connected to the regulator.
3. Check that there are no gas leaks in the gas supply system. See Leak Testing.
4. Check that the venturi tube is properly located over the gas valve orifices.
5. Check that Main Burner ignition wire is connected.
6. Read carefully all instructions contained on the information plate attached to the smoker.
7. **WARNING: Open Door before lighting.**
8. Set control knobs to "OFF" and turn on the gas supply.
9. **For Main Burner:**  
Push and turn main burner control knob to "HIGH"  
Turn igniter Clockwise.  
Burner should ignite within 5 seconds.

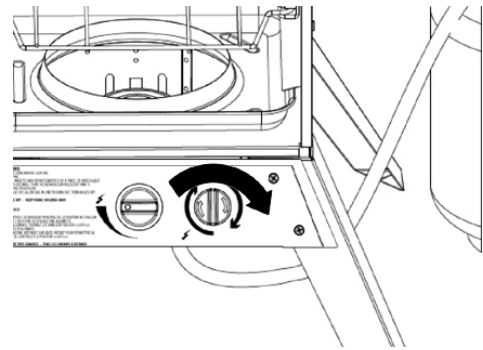
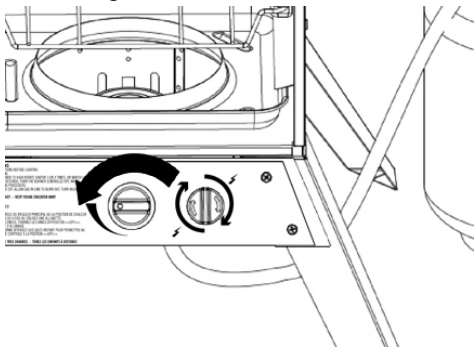

## To light burner with a match

follow steps 1 thru 8 above.

Using the match holder provided with the smoker lower a lit match to the burner.

Push and turn the control knob to "HIGH".

Burner should ignite within 5 seconds.

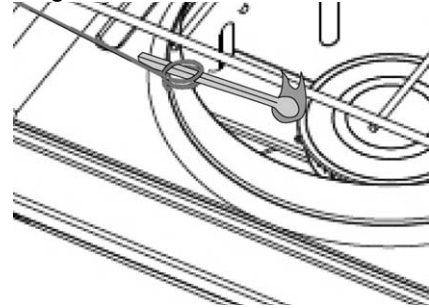

## 10. Caution - Check your Smoker after lighting.

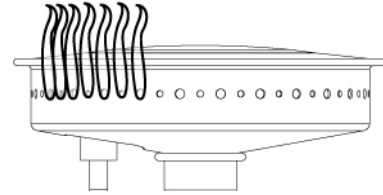

All the ports on the burner should show a 2.5cm (1in) flame on "HIGH" setting.

If any of the following symptoms occur there is probably a blockage in the venturi tubes. Shut off gas at once and clean the venturi tubes. See "Venturi Tubes".

1. You smell gas.
2. If a flashback fire occurs.
3. Your smoker heats unevenly.
4. The burners make popping noises.

## IF BURNER DOES NOT IGNITE:

1. Push and turn control knob to "OFF".  
Wait 5 minutes, and then try again with control knob set at medium.
2. If the burner will not light, consult "Trouble Shooting Guide". If problem cannot be resolved, do not attempt to operate the appliance; contact your dealer or approved service centre.

## SHUT DOWN

1. Turn off cylinder valve.
2. Turn control knobs to "OFF".

# OPERATION

## THIS APPLIANCE IS NOT INTENDED FOR COMMERCIAL USE

**Burn-off.** Before cooking in your gas smoker for the first time, burn off the smoker to rid it of any odors or foreign matter as follows:

Remove cooking grids and warming rack and wash in mild soap and water. Ignite the burner. Close the door and operate the smoker for **20 minutes** with the control knobs set at "**HIGH**". Turn the gas off at the source. Turn the control knob to "Off". Let the appliance cool down, replace the grids. You are now ready to use the appliance.

**Preheating.** It is necessary to preheat the smoker with the door closed for a short time before cooking certain foods. Food that requires a HIGH cooking temperature needs a period of six to ten minutes to preheat; food that requires a lower cooking temperature needs only a period of two to five minutes. There is no need to preheat for food that will be slow cooked.

**Door Position.** During cooking the door should always be closed. A closed door helps maintain a constant cooking temperature.

**Vent Position.** The exhaust vent at the back of the cabinet is adjustable to control cooking temperatures and the convectional flow of the smoke. **When adjusting the vent during cooking use an oven mitt the vent will be HOT.** Opening the vent will increase the rate of smoke and heat passing through. Closing will stop the flow.

**Grids Position.** The grids are easily adjusted by moving the position of the grid support bracket. Make sure that the brackets are placed in holes that are level. The brackets across from each other should also be level.

**Hanging Hooks.** There are a set of hanging hooks provided to use to suspend food below the grids. These hooks help in the cooking of foods like sausage, whole fish and chicken wings.

**Smoker Box.** This cast iron box is designed to hold and burn hard wood chips. The goal of wood chips is to impart a smoked flavor to the foods. At a low heat setting water soaked woodchips will begin to smoke in about 15 to 20 minutes. Wood chips are a key element in this style of slow cooking. Purchase Grillpro brand wood chips at your local Grillpro dealer and follow the manufactures instructions on the packaging to prepare them for use in your Grillpro smoker.

**Water Bowl.** The function of the water bowl is to keep the cooking environment moist and to add flavor. The addition of flavor comes in two forms. First is the addition of juice, beer or wine to the water bowl. The second is falling fat drippings collected in the water bowl. Both are vaporized and circulated in the smoker and seasoning the same food. Always fill the water bowl half way before you begin cooking and maintain the level in the water bowl while you continue to cook.

**Low Setting.** With the control knob at LOW, the temperature inside the smoker is approximately 200° F (93° C). Use this setting for all smoke cooking and when cooking very lean food such as fish. The slow cooking process is long, usually over several hours. Make sure food has reached the appropriate internal temperature. Consult the meat thermometer guide.

**Medium Setting.** With the control knob at medium, the temperature inside the smoker is approximately 300° F (150°C) with the door closed.

**HIGH Setting.** With the control knob at HIGH, the internal temperature of the cabinet is approximately 400° F (205° C) when the smoker is warmed up. Use this setting for warm-up, oven style cooking and for burning food residue from the cooking grids and cabinet after the cookout is over.

**These temperatures are approximate only and vary with the outside temperature and the amount of wind present.**

### PREPARATION:

1. Prepare food in advance to avoid delay and timing problems. If using marinade or spices, they should be applied before placing meat on the cooking grid.
2. Organize the area around the smoker to include forks, tongs, oven mitts, sauces and seasonings, to allow you to stay in the vicinity of the smoker while cooking.
3. Leave excess fat on the meat to maximize the flavor of slow cooked foods.
4. To avoid the problem of food sticking to the cooking grid, coat the grids with vegetable oil or non-stick spray before lighting the burner.
5. Wood chips should be soaked according to manufactures instructions prior to starting the smoker.
6. Pre-heat the smoker to the desired temperature with the door closed, before starting to cook.
7. Vegetables are best done in aluminum foil with enough moisture to create steam. Cooking time for vegetables will be similar to baking or steaming on the electric range.
8. Check the gas supply before starting the smoker.

### MEAT THERMOMETER GUIDE:

BEEF/LAMB	RARE	55°C	(130°F)
BEEF/LAMB	MEDIUM	66°C	(150°F)
BEEF/LAMB	WELL DONE	71°C	(160°F)
VEAL	WELL DONE	65°C	(150°F)
PORK	WELL DONE	77°C	(170°F)
POULTRY	WELL DONE	77°C	(170°F)

**When slow cooking with your smoker, use a meat thermometer for best results.**



# COOKING TECHNIQUES

**Smoker cooking.** Smoker cooking or slow cooking is a more time consuming form of barbeque that produces excellent results with regards to flavor. Slow cooked meats become tender and full of moist rich flavor from the process of smoke and liquid infusion. The main characteristics of this style of cooking are, low temperatures over extended periods of time, wood smoke generated from hard wood chips and a moist cooking environment created by steam from the water bowl.

**Types of food.** Slow smoker cooking is useful and delicious for all types of meats. Pork, beef, poultry, fish and lamb are all excellent meat to cook in the Grillpro smoker. As a general guide lean meats will need more liquid to keep the moist and tender over the long cooking process. While meats higher in fat will self baste during cooking.

Since the slow cooking process use low heat, cooking times are much longer then a barbeque grill. Any Guidelines for cooking time should be understood as only approximate and doneness of meats should be determined by thermometer reading of internal temperature.

COOKING TIMES ARE ONLY APPROXIMATE AND INTERNAL TEMPERATURES SHOULD BE TAKEN TO INSURE FOOD SAFETY

MEAT	WEIGHT	APPROXIMATE COOKING TIME	WELL DONE INTERNAL TEMP.
<b>SLOW COOKING TEMP 200-220°F 90-105°C</b>			
PORK ROAST		1.5 HOURS/LBS	160-170°F 70-77°C
SPARERIBS	4-6LBS	4-5 HOURS	160-170°F 70-77°C
BEEF BRISKET		1.5 HOURS/LBS	170°F 77°C
BEEF ROAST		1.5 HOURS/LBS	180°F 82°C
WHOLE CHICKEN	2-3 LBS	2-3 HOURS	185°F 85°C
WHOLE FISH	FULL GRID	1.5-2.5 HOURS	MEAT FLAKES
LEG OF LAMB	5-7 LBS	3-5 HOURS	145-170°F 63-77°C

**Wood chips.** Different hardwoods Oak, Maple and Apple just to name a few are available as smoking chips intended for use in barbeques and smokers. It is best to use wood chips that have been prepared for smoking as they are safe. You do not want to use most soft woods (Pine, Spruce) because these contain lots of sap and will impart a bad taste to food.

Prepare wood chips according to the manufacture's instructions. Usually chips should be soaked in water for 30 minutes prior to use. Fill the smoker box with soaked wood chips before starting the smoker. While you are cooking if you need to add additional wood chips, take care and use a long handled tong or pliers to remove the lid of the smoker box. Drop freshly soaked wood chips into the box while it is still inside the smoker. **Do not remove the hot smoker box until it has cooled**

**Liquid infusion.** The addition of liquid is essential to keeping foods moist and tender during the slow cooking process. The water bowl should be filled half way with liquid. The liquid itself can be water or a desired flavor like fruit juice, beer, wine, vinegar, oils, sauces that are mostly water and a variety of spices can be added to a mix. Maintain the level of the water bowl though out the cooking process.

# Recipes

---

## SMOKED SHREDDED PORK BARBECUE SANDWICHES

### serves 8 - preparation time 0:20

Pulled pork is a Southern classic! The pork shoulder is cooked long and slow, then shredded and served with a tangy barbecue sauce. The pork shoulder is a less tender cut of meat, which must be cooked on the barbecue for between 5 and 8 hours or 1.5hrs per pound.

- 1..... large pork shoulder 6 lb. bone-in with fat covering attached
- 1/2 cup..... Lemon Chili Herb Rub
- 1 1/2cup..... favorite barbecue sauce
- 8..... large crusty rolls
- 2cups..... apple or hickory wood chips

### Lemon chili herb rub

- 1/4cup.....sugar
- 1/4cup.....kosher salt
- 3tbs..... chili powder
- 1tsp..... ground cumin
- 1tsp..... dried oregano
- 1tsp..... ground coriander
- 1tsp..... dry mustard
- 1tbs..... lemon zest, finely grated

### Prepare pork:

Sprinkle the pork shoulder generously with rub and massage in on all sides. Set aside for minimum 1 hour, or overnight in the refrigerator to allow flavors to penetrate the meat.

### Prepare Smoker:

Soak wood chips in water for a minimum of one hour, before starting the smoker. Place an even layer of soaked chips in the smoker box, and place the box on the supports. Fill water bowl half way with desired flavoring liquid. If you are using a juice or soda with high sugar content, mix with 50% water to avoid caramelizing the sugars. Ensure that fluid level is maintained throughout cooking.

Light smoker set heat control to low, and close door.

### Smoke pork:

When the smoker has reached 200F place the pork, fat side up, on a rack in the center of the cabinet. The pork will need to cook for approximately 1.5hrs per pound. The pork should be checked for doneness with a meat thermometer to ensure internal temperature of 165F-175F.

\*To adjust the level of smoke flavor in the meat, vary the amount of wood chips used throughout the cooking time.

Meat will be so tender that it can be shredded, or pulled with a fork!

### Serve:

Let pork sit for 15 minutes, covered with foil. Shred or cut the pork and mix with your favorite warmed sauce. Serve it on crusty buns.

# Recipes

---

## Barbecued back ribs

**Serves 6 - preparation time 0:15**

3 lbs..... pork back ribs  
2 cups..... pecan or hickory wood chips

### Sauce

1 cup..... ketchup  
2 tbs..... brown sugar  
1/2 cup..... water  
1/3 cup..... worcestershire sauce  
1 tbs..... chili powder dash hot pepper sauce  
Salt and pepper to taste

### Prepare Ribs:

Peel the membrane off the back of the ribs using your fingers. (This makes an enormous difference in the tenderness of the ribs.) Cut each sleeve or rack of ribs into 6" sections. Sprinkle with salt and pepper.

### Prepare Sauce:

Combine sauce ingredients in a pot, bring to a boil and then simmer until thickened.

### Prepare Smoker:

Soak wood chips in water for a minimum of one hour, before starting the smoker. Place an even layer of soaked chips in the smoker box, and place the box on the supports. Fill water bowl half way with desired flavoring liquid. If you are using a juice or soda with high sugar content, mix with 50% water to avoid caramelizing the sugars. Ensure that fluid level is maintained throughout cooking.

Light smoker set heat control to low, and close door.

### Smoke Ribs:

When the smoker has reached 200°F-220°F (93°C-105°C) place the ribs, bone side down on the racks of the smoker.

The ribs will need to cook for approximately 4-5hours. Baste ribs with prepared sauce once per hour or more. The ribs should be checked for doneness with a meat thermometer to ensure internal temperature of 165°F-175°F (74°C-79°C).

\*To adjust the level of smoke flavor in the meat, vary the amount of wood chips used throughout the cooking time.

### Serve:

Serve ribs with leftover sauce.

## Smoked prime rib of beef

**Serves 12 - preparation time 0:05**

5-10 lbs..... prime rib of beef, rolled and tied  
5..... cloves garlic, slivered  
6 tbs..... Dijon mustard  
2 tbs..... fresh thyme, chopped  
1 tbs..... freshly ground black pepper  
2 cups..... Mesquite or alder wood chips

### Prepare Beef:

Cut garlic cloves into slivers and insert into the roast. Combine the Dijon mustard, thyme and pepper and spread mixture over the roast.

### Prepare Smoker:

Soak wood chips in water for a minimum of one hour, before starting the smoker. Place an even layer of soaked chips in the smoker box, and place the box on the supports. Fill water bowl half way with desired flavoring liquid. This recipe works very well with red wine and water mixed 50/50. Ensure that fluid level is maintained throughout cooking.

Light smoker set heat control to low, and close door.

### Smoke Ribs:

When the smoker has reached 220°F-250°F (105°C-120°C) place the roast on a rack in the middle of the cabinet. Cook roast for 3.5hrs – 5.5hrs or approximately 1/2hr per pound.

The roast should be checked for doneness with a meat thermometer to ensure internal temperature of 140°F (60°C) (medium rare).

\*To adjust the level of smoke flavor in the meat, vary the amount of wood chips used throughout the cooking time.

### Serve:

Let stand 20 minutes before carving.

# MAINTENANCE

## PERIODIC MAINTENANCE

After you have finished, prepare for the next cookout by burning off any residue of food from the grids in the following manner:

### Cooking Grids

Remove all food from the grids, turn the control knob to "HIGH", and operate the smoker with the door closed for 5 to 10 minutes or until smoking stops. Turn the gas cylinder valve to OFF, then the control knob to OFF. Use a long-handled **brass** wire brush to clean the grids. Remember that the smoker is hot, so wear kitchen mitts or use a pot-holder to handle the brush. You do not have to wash the grids after each cookout, but if you wish to do so, use a mild soap and water solution, then rinse them thoroughly. **Never use a commercial oven cleaner.**

### Grease Tray

The grease tray is located on the bottom of the cabinet around the burner. The grease tray should be checked and cleaned regularly to prevent grease from overflowing onto your patio and onto the smoker controls.

### General Cleaning

When the smoker is cold, remove the grids. Cover three quarters of the cooking grids with aluminum foil, shiny side down. Ignite the burner; operate the smoker on HIGH with the door closed for 10 minutes or until smoking stops. Turn the gas cylinder valve to OFF, turn the control knob to OFF. When the smoker is cool, remove the foil and grids. Then clean the interior of the bottom cabinet by scraping the sides and vacuuming.

## ANNUAL MAINTENANCE

To ensure safe and efficient performance, the following components should be inspected and cleaned at least once per year or after any period of storage exceeding one month.

### Burner

Remove burner and inspect for cracks and deterioration. Clean venturi tube using a pipe cleaner or venturi brush to eliminate any blockages caused by spiders or insects. See "Venturi Tube".

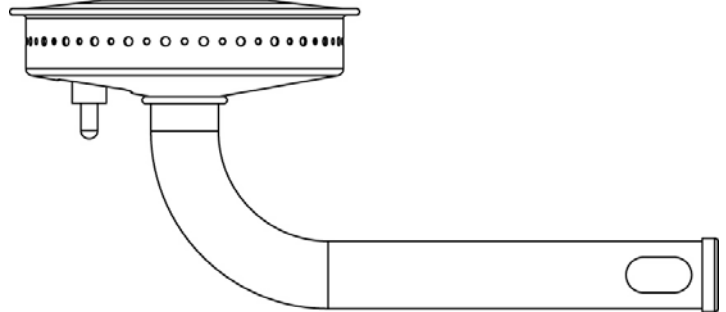

While burner is removed, clean interior of bottom oven by scraping the sides and vacuuming.

### Hose

Inspect and replace if necessary. See "Hose and Regulator".

### Exterior Finish

Rusting is a natural oxidation process and may appear on cast-iron and steel parts. Rust will not affect short term performance of your smoker.

### Replacement Parts

If a problem is found with the regulator, hose, burner, or control valves, **do not** attempt repair. See your dealer, approved service centre, or contact the factory for repairs or replacement parts. To ensure optimum performance, use only original OMC replacement parts.

### Leak Test

After reconnecting a gas cylinder, be sure to check for leaks. See "Leak Testing"

# TROUBLE SHOOTING

PROBLEM	POSSIBLE CAUSE	CORRECTIVE ACTION
SMELL OF GAS	<b>SHUT OFF LP GAS CYLINDER VALVE AT ONCE. DO NOT USE THE APPLIANCE UNTIL LEAK IS SEALED.</b>	
Leak detected at cylinder, regulator or other connection.	<ol style="list-style-type: none"> <li>1. Regulator fitting loose.</li> <li>2. Gas leak in hose/regulator or control valves.</li> </ol>	<ol style="list-style-type: none"> <li>1. Tighten fitting and "Leak Test".</li> <li>2. See authorized service centre.</li> </ol>
Flame flashback beneath control panel.	<ol style="list-style-type: none"> <li>1. Venturi blocked.</li> </ol>	<ol style="list-style-type: none"> <li>1. Remove burner, clean venturi. See "Venturi Tube".</li> </ol>
Burner will not light.	<ol style="list-style-type: none"> <li>1. Out of LP Gas.</li> <li>2. Igniter wire not connected.</li> <li>3. Igniter electrode misaligned on burner.</li> <li>4. Igniter malfunctions.</li> <li>5. Regulator is not fully connected to the cylinder valve.</li> <li>6. Burner valve left open while cylinder valve was opened causing the Flow Limiting Device to activate.</li> <li>7. A leak in the system causing the Flow Limiting Device to activate.</li> <li>8. Venturi blocked.</li> <li>9. Venturi not aligned with valve orifice.</li> <li>10. Orifice blocked.</li> <li>11. Hose is twisted.</li> </ol>	<ol style="list-style-type: none"> <li>1. Refill LP Gas Cylinder.</li> <li>2. Connect electrode wires to burner.</li> <li>3. Realign electrode.</li> <li>4. Use "Manual Lighting" Procedure.</li> <li>5. Tighten the regulator hand wheel.</li> <li>6. Close burner and cylinder valves. Open cylinder valve slowly, then open burner valve to light.</li> <li>7. Leak test connections to determine loose fitting. Tighten fitting. Leak test system.</li> <li>8. Remove burner, clean venturi. See "Venturi Tubes".</li> <li>9. Realign venturi to orifice. See "Venturi Tube".</li> <li>10. Remove burner, clean orifice with a pin or fine wire. Do not attempt to drill orifice.</li> <li>11. Straighten hose. Keep away from bottom casting.</li> </ol>
Decreasing heat, "popping sound".	<ol style="list-style-type: none"> <li>1. Out of LP Gas.</li> <li>2. Venturi blocked.</li> </ol>	<ol style="list-style-type: none"> <li>1. Refill LP Gas Cylinder.</li> <li>2. Remove burner, clean venturi. See "Venturi Tube".</li> </ol>
"Flare-ups" or grease fires.	<ol style="list-style-type: none"> <li>1. Excessive grease buildup.</li> <li>2. Excessive heat.</li> </ol>	<ol style="list-style-type: none"> <li>1. See "Maintenance".</li> <li>2. Turn burner control to a lower setting.</li> </ol>
Humming noise from regulator.	<ol style="list-style-type: none"> <li>1. Cylinder valve turned on too quickly.</li> </ol>	<ol style="list-style-type: none"> <li>1. Turn cylinder valve on slowly.</li> </ol>
Yellow Flame.	<ol style="list-style-type: none"> <li>1. Some yellow flame is normal. If it becomes excessive the venturi may be blocked.</li> <li>2. Burner ports blocked.</li> </ol>	<ol style="list-style-type: none"> <li>1. Remove burner, clean venturi. See "Venturi Tube".</li> <li>2. Remove burner &amp; clean with soft bristle brush.</li> </ol>
Inside of cabinet appears to be peeling.	<ol style="list-style-type: none"> <li>1. This is a build up of grease. The inside of the lid is not painted.</li> </ol>	<ol style="list-style-type: none"> <li>1. Clean with stiff bristle brush or scraper.</li> </ol>

# WARRANTY

The OMC Warranty is effective from date of purchase and is limited to the repair or replacement of parts at no charge which prove to be defective under normal domestic use.

In Canada & the United States replacement is FOB Factory.

In all other countries replacement is FOB OMC Distributor. (consult your Dealer for name of OMC Distributor).

All other costs are the responsibility of the owner.

This warranty is extended only to the original purchaser as indicated on the warranty registration and applies only to products sold at retail and only when used in country where purchased. (Different types of gas used in different countries require appropriate valves, orifices and regulators.)

## WHAT IS COVERED

High Heat Coated Cook Box		1 year
Burner		1 year
All Remaining Parts	Excluding Tank	1 year

## WHAT IS NOT COVERED

Any failures or operating difficulties due to accident, abuse, misuse, alteration, misapplication, vandalism, improper installation or improper maintenance or service, or failure to perform normal and routine maintenance, including but not limited to damage caused by insects within the burner tubes, as set out in the owner's manual.

Deterioration or damage due to severe weather conditions such as hail, hurricanes, earthquakes or tornadoes, discoloration due to exposure to chemicals either directly or in the atmosphere.

Shipping or transportation costs.

Removal or re-installation costs.

Labor costs for installation and repair.

Cost of service calls.

Liability for indirect, or consequential damages.

## REPLACEMENT PARTS

"Genuine OMC Gas smoker Parts" must always be used for replacement. Use of any other parts will automatically nullify the above warranty.

## WARRANTY CLAIMS

All warranty is handled directly by OMC. Parts must be returned to OMC Warranty Department, shipping charges prepaid, accompanied by Model #, Serial #, and if your smoker is not registered, proof of purchase (copy of sales slip or invoice). If inspection confirms the defect, OMC will repair or replace such part in accordance with the terms of the warranty.

On receipt of letter or fax (not by phone) OMC may at its option not require part or parts to be returned.

Name		Model #	
Address		Date of purchase	
City, State/Province		Name of dealer	
Postal/Zip Code		Part # (see assembly manual)	
E-mail Address			
Phone #		Fax #	
Problem			

## BURNERS

The life of OMC burners (made of stainless steel) depends almost entirely on proper use, cleaning and maintenance. This warranty does not cover failure due to improper use and maintenance. In this event the warranty grants the owner the option of buying a new burner at the following discounts from current price. During 3rd year - 50%, 4th year - 40%, 5th year - 25%. Shipping and handling charges are the responsibility of the owner.

## PORCELAIN PAINT COATING

Some OMC cook boxes and cooking grids are coated with a durable porcelain enamel. Porcelain is essentially a glass coating. Some chipping may occur if mishandled. This will not affect the use or performance of the part. These parts are not warranted against chipping or rusting. If some rust appears, remove the rust with a scrub pad and coat with cooking oil. Similar care should be taken with high heat paint finishes.

## LP GAS CYLINDER

OMC does not manufacture LP Gas Cylinders. The LP Gas Cylinder manufacturer is responsible for the materials, workmanship and performance of the cylinder. If the cylinder has a defect, malfunctions, or you have a question regarding the cylinder, contact your dealer or the cylinder manufacturer.