



Recessed Hole



Pre-Checked

- Durable log construction.
- Exclusive Char-log® finish and design
- Patent pending crack resistant design and process

IMPORTANT: READ CAREFULLY BEFORE BEGINNING!

1. Do not tighten bolts until fully assembled.
2. Recessed holes to face outward.
3. Insert bolts with washer and secure with washer and nut.
4. Pre-checked side must always face downward or inward.

- Special Char-log® heat curing, preserving, finishing Process resists mildew, mold, and stains
- Varnished to preserve Char-log® finish

TX 93723 END TABLE

Parts

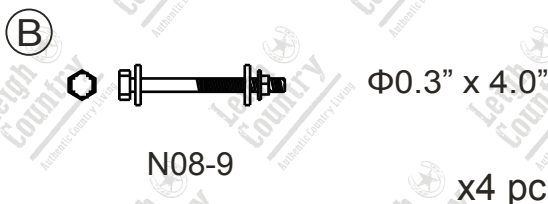
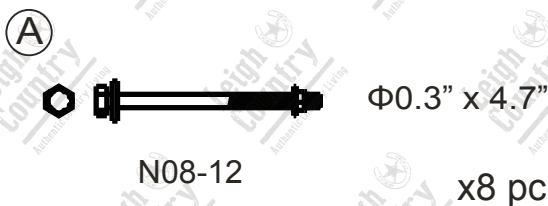
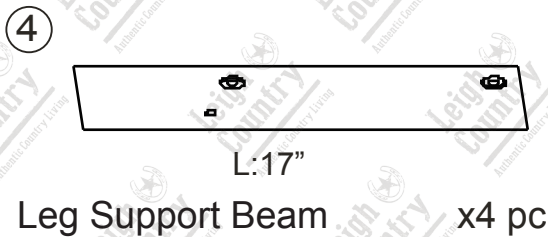
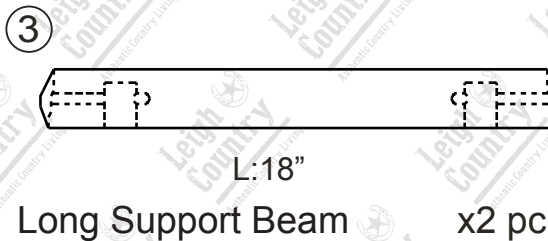
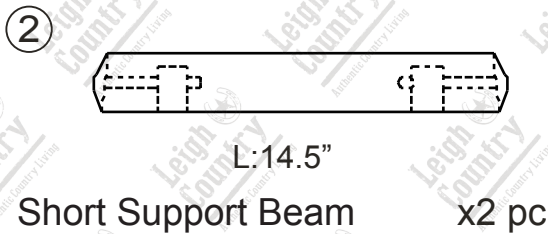
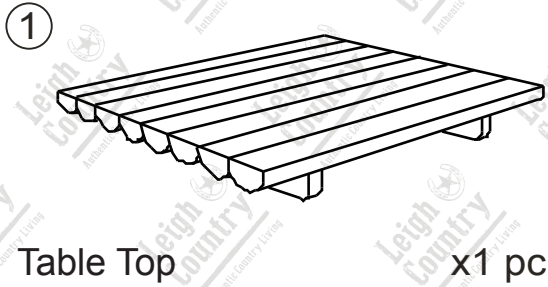

Assemble

NOTE: KEEP ALL NUTS AND BOLTS LOOSE DURING ASSEMBLY

STEP 1

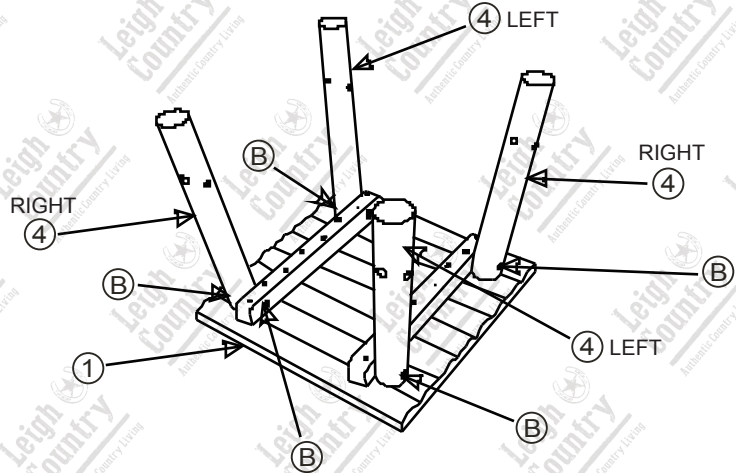

STEP 2

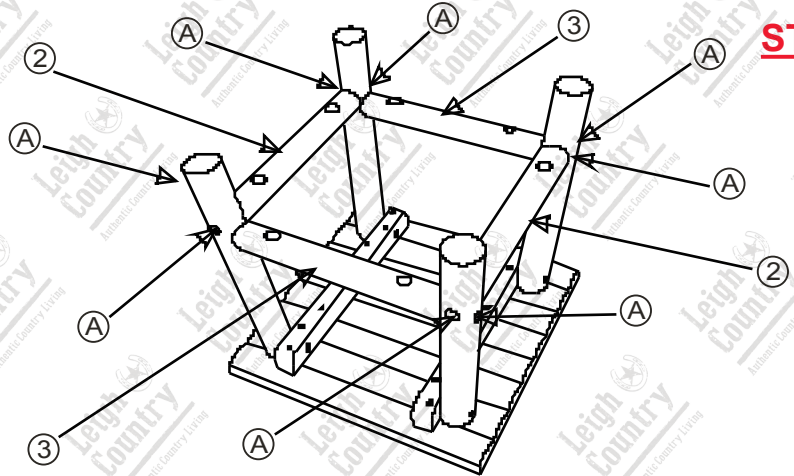

STEP 3



TIGHTEN ALL SCREWS LAST