

Flush & Bevel Trim Bits

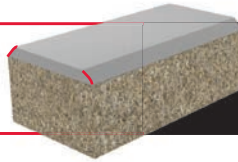

STRAIGHT, SPIRAL & TRIM BITS

ITEM NUMBER	OVERALL DIA.	CARBIDE HEIGHT	MINOR HEIGHT	ANGLE	SHANK DIA.	OVERALL LENGTH
41-300	15/32"	1/2"	3/16"	30°	1/4"	1-25/32"
41-402	7/8"	5/8"	39/64"	45°	1/4"	2-1/4"
68-100*	1/4"	3/8"	11/64"	7°	1/4"	1-1/2"

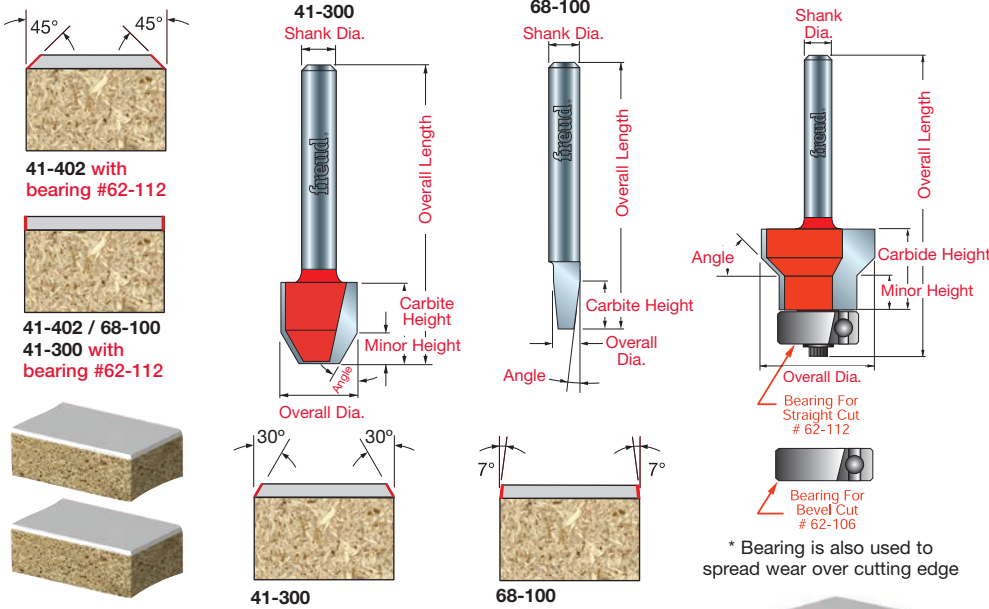

USE IN

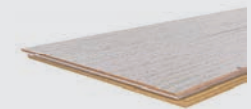

Table Router Hand Router

APPLICATION

Trimming plastic laminate with straight or beveled edge on a router equipped with a guide system. Bit 41-402 is self-guided and comes with two bearings that spread wear evenly on the cutting edge and allow the bit to straight trim or create a 45° bevel.

MATERIALS



All Plastic Laminates

ROUTER BITS

Radius Laminate Trim Bit

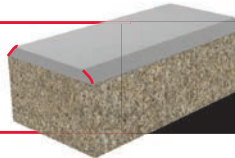

STRAIGHT, SPIRAL & TRIM BITS

ITEM NUMBER	OVERALL DIA.	BEARING DIA.	CARBIDE HEIGHT	SHANK DIA.	OVERALL LENGTH
41-502	1/2"	3/8"	1/16"	1/4"	2"

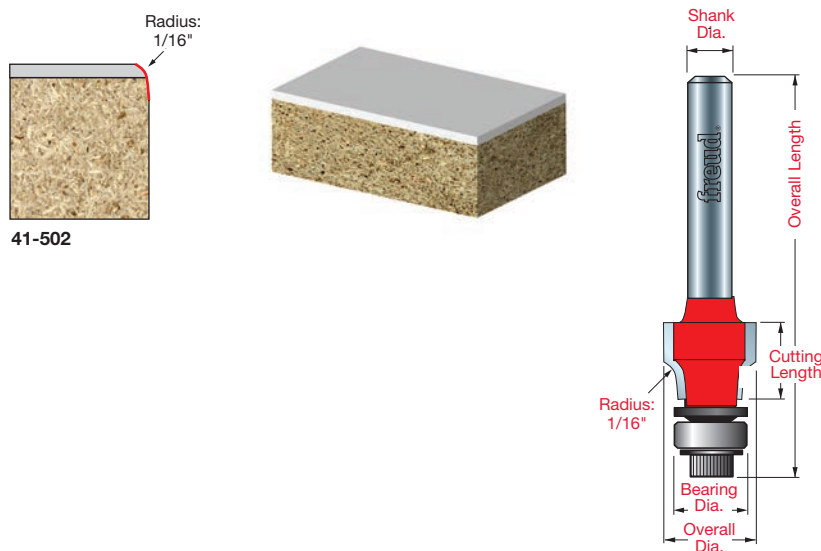

USE IN

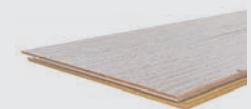

Table Router Hand Router

APPLICATION

Routs plastic laminate edges flush and rounded in a single pass-reducing time and aggravation. Unique cutting geometry produces an ultra-smooth finish on laminate edges.

MATERIALS



Countertop-grade laminates including Formica®, Wilsonart® and similar materials