

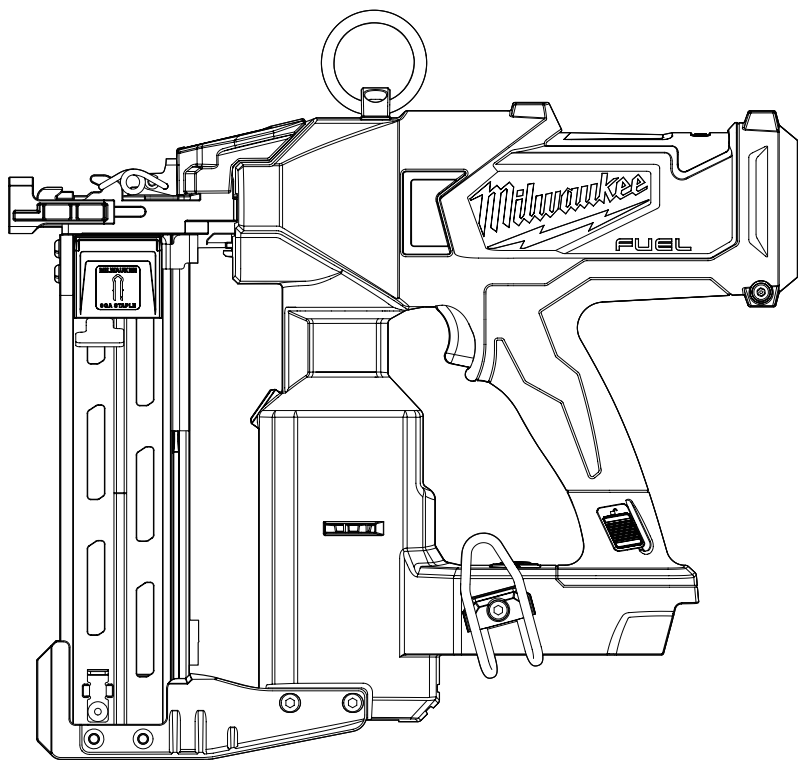

OPERATOR'S MANUAL
MANUEL de L'UTILISATEUR
MANUAL del OPERADOR



Cat. No. / No de cat.
2843-20

M18 FUEL™ UTILITY FENCING STAPLER
AGRAFEUSE DE CLÔTURE UTILITAIRE M18 FUEL™
GRAPADORA UTILITARIA PARA CERCAS M18 FUEL™



WARNING To reduce the risk of injury, user must read and understand operator's manual.

AVERTISSEMENT Afin de réduire le risque de blessures, l'utilisateur doit lire et bien comprendre le manuel.

ADVERTENCIA Para reducir el riesgo de lesiones, el usuario debe leer y entender el manual.

GENERAL POWER TOOL SAFETY WARNINGS

WARNING Read all safety warnings, instructions, illustrations and specifications provided with this power tool. Failure to follow all instructions listed below may result in electric shock, fire and/or serious injury. **Save all warnings and instructions for future reference.** The term "power tool" in the warnings refers to your mains-operated (corded) power tool or battery-operated (cordless) power tool.

WORK AREA SAFETY

- **Keep work area clean and well lit.** Cluttered or dark areas invite accidents.
- **Do not operate power tools in explosive atmospheres, such as in the presence of flammable liquids, gases or dust.** Power tools create sparks which may ignite the dust or fumes.
- **Keep children and bystanders away while operating a power tool.** Distractions can cause you to lose control.

ELECTRICAL SAFETY

- **Power tool plugs must match the outlet. Never modify the plug in any way. Do not use any adapter plugs with earthed (grounded) power tools.** Unmodified plugs and matching outlets will reduce risk of electric shock.
- **Avoid body contact with earthed or grounded surfaces, such as pipes, radiators, ranges and refrigerators.** There is an increased risk of electric shock if your body is earthed or grounded.
- **Do not expose power tools to rain or wet conditions.** Water entering a power tool will increase the risk of electric shock.
- **Do not abuse the cord. Never use the cord for carrying, pulling or unplugging the power tool. Keep cord away from heat, oil, sharp edges or moving parts.** Damaged or entangled cords increase the risk of electric shock.
- **When operating a power tool outdoors, use an extension cord suitable for outdoor use.** Use of a cord suitable for outdoor use reduces the risk of electric shock.
- **If operating a power tool in a damp location is unavoidable, use a ground fault circuit interrupter (GFCI) protected supply.** Use of an GFCI reduces the risk of electric shock.

PERSONAL SAFETY

- **Stay alert, watch what you are doing and use common sense when operating a power tool. Do not use a power tool while you are tired or under the influence of drugs, alcohol or medication.** A moment of inattention while operating power tools may result in serious personal injury.
- **Use personal protective equipment. Always wear eye protection.** Protective equipment such as a dust mask, non-skid safety shoes, hard hat or hearing protection used for appropriate conditions will reduce personal injuries.
- **Prevent unintentional starting. Ensure the switch is in the off-position before connecting to power source and/or battery pack, picking up or carrying the tool.** Carrying power tools with your finger on the switch or energizing power tools that have the switch on invites accidents.
- **Remove any adjusting key or wrench before turning the power tool on.** A wrench or a key left attached to a rotating part of the power tool may result in personal injury.
- **Do not overreach. Keep proper footing and balance at all times.** This enables better control of the power tool in unexpected situations.

- **Dress properly. Do not wear loose clothing or jewelry. Keep your hair and clothing away from moving parts.** Loose clothes, jewelry or long hair can be caught in moving parts.
- **If devices are provided for the connection of dust extraction and collection facilities, ensure these are connected and properly used.** Use of dust collection can reduce dust-related hazards.
- **Do not let familiarity gained from frequent use of tools allow you to become complacent and ignore tool safety principles.** A careless action can cause severe injury within a fraction of a second.

POWER TOOL USE AND CARE

- **Do not force the power tool. Use the correct power tool for your application.** The correct power tool will do the job better and safer at the rate for which it was designed.
- **Do not use the power tool if the switch does not turn it on and off.** Any power tool that cannot be controlled with the switch is dangerous and must be repaired.
- **Disconnect the plug from the power source and/ or remove the battery pack, if detachable, from the power tool before making any adjustments, changing accessories, or storing power tools.** Such preventive safety measures reduce the risk of starting the power tool accidentally.
- **Store idle power tools out of the reach of children and do not allow persons unfamiliar with the power tool or these instructions to operate the power tool.** Power tools are dangerous in the hands of untrained users.
- **Maintain power tools and accessories. Check for misalignment or binding of moving parts, breakage of parts and any other condition that may affect the power tool's operation. If damaged, have the power tool repaired before use.** Many accidents are caused by poorly maintained power tools.
- **Keep cutting tools sharp and clean.** Properly maintained cutting tools with sharp cutting edges are less likely to bind and are easier to control.
- **Use the power tool, accessories and tool bits etc. in accordance with these instructions, taking into account the working conditions and the work to be performed.** Use of the power tool for operations different from those intended could result in a hazardous situation.
- **Keep handles and grasping surfaces dry, clean and free from oil and grease.** Slippery handles and grasping surfaces do not allow for safe handling and control of the tool in unexpected situations.

BATTERY TOOL USE AND CARE

- **Recharge only with the charger specified by the manufacturer.** A charger that is suitable for one type of battery pack may create a risk of fire when used with another battery pack.
- **Use power tools only with specifically designated battery packs.** Use of any other battery packs may create a risk of injury and fire.
- **When battery pack is not in use, keep it away from other metal objects, like paper clips, coins, keys, nails, screws or other small metal objects, that can make a connection from one terminal to another.** Shorting the battery terminals together may cause burns or a fire.
- **Under abusive conditions, liquid may be ejected from the battery; avoid contact. If contact accidentally occurs, flush with water. If liquid contacts eyes, additionally seek medical help.** Liquid ejected from the battery may cause irritation or burns.

- Do not use a battery pack or tool that is damaged or modified. Damaged or modified batteries may exhibit unpredictable behavior resulting in fire, explosion or risk of injury.
- Do not expose a battery pack or tool to fire or excessive temperature. Exposure to fire or temperature above 265°F (130°C) may cause explosion.
- Follow all charging instructions and do not charge the battery pack or tool outside the temperature range specified in the instructions. Charging improperly or at temperatures outside the specified range may damage the battery and increase the risk of fire.

SERVICE

- Have your power tool serviced by a qualified repair person using only identical replacement parts. This will ensure that the safety of the power tool is maintained.
- Never service damaged battery packs. Service of battery packs should only be performed by the manufacturer or authorized service providers.

STAPLER SAFETY WARNINGS

- Always assume that the tool contains fasteners. Careless handling of the fastener can result in unexpected firing of fasteners and personal injury.
- Do not point the tool towards yourself or anyone nearby. Unexpected triggering will discharge the fastener causing an injury.
- Do not actuate the tool unless the tool is placed firmly against the workpiece. If the tool is not in contact with the workpiece, the fastener may be deflected away from your target.
- Disconnect the tool from the power source when the fastener jams in the tool. While removing a jammed fastener, the stapler may be accidentally activated if it is plugged in.
- Use caution while removing a jammed fastener. The mechanism may be under compression and the fastener may be forcefully discharged while attempting to free a jammed condition.
- Do not use this stapler for fastening electrical cables. It is not designed for electric cable installation and may damage the insulation of electric cables thereby causing electric shock or fire hazards.
- Prior to each use, check workpiece contact and trigger for correct operation. Do not disassemble or clamp parts of the workpiece contact, trigger, or driving mechanism. This will cause unexpected actuation, resulting in serious injury.
- Do not engage in horseplay. The discharged fasteners are projectiles capable of causing serious injury.
- Do not remove, tamper with, or otherwise cause the tool operating controls to become inoperable. This will cause unexpected actuation, resulting in serious injury.
- Do not operate a tool if any portion of the tool operating controls is inoperable, disconnected, altered, or not working properly. This will cause unexpected actuation, resulting in serious injury.

- Always keep hands and body away from discharge area of the tool. Never attempt to clear a jammed workpiece contact by grasping the discharge area of the tool. Fasteners discharged from tool can cause serious injury if they contact hands or body.
- Do not drive fasteners close to the edge of the workpiece. Fasteners can slip off corners and edges or penetrate through thin material, making them projectiles capable of causing serious injury.
- Use the tool only for the intended purpose. Do not abuse the tool. Do not use as a hammer, stamp or engrave information onto parts, drop or impact the tool or otherwise apply excess force to the tool in use. Do not mount the tool to stands or modify it for stationary use.

- For best results, use only with energy absorbing lanyards. Ropes, straps or chains may break and cause failure. Do not use with lanyards at full tension.

▲WARNING To reduce the risk of injury, when working in dusty situations, wear appropriate respiratory protection or use an OSHA compliant dust extraction solution.

- Always use common sense and be cautious when using tools. It is not possible to anticipate every situation that could result in a dangerous outcome. Do not use this tool if you do not understand these operating instructions or you feel the work is beyond your capability; contact Milwaukee Tool or a trained professional for additional information or training.







• Maintain labels and nameplates. These carry important information. If unreadable or missing, contact a MILWAUKEE service facility for a free replacement.

▲WARNING Some dust created by power sanding, sawing, grinding, drilling, and other construction activities contains chemicals known to cause cancer, birth defects or other reproductive harm. Some examples of these chemicals are:

- lead from lead-based paint
- crystalline silica from bricks and cement and other masonry products, and
- arsenic and chromium from chemically-treated lumber.

Your risk from these exposures varies, depending on how often you do this type of work. To reduce your exposure to these chemicals: work in a well ventilated area, and work with approved safety equipment, such as those dust masks that are specially designed to filter out microscopic particles.

SYMBOLGY

	Volts
	Direct Current
	Read Operator's Manual
	Wear Eye Protection
	Keep Hands Away
	UL Listing for Canada and U.S.

SPECIFICATIONS

Cat. No.	2843-20
Volts.	18 DC
Battery Type	M18™
Charger Type	M18™
Staple Length	1.5"-2"
Staple Size (Diameter)9 GA
Magazine Capacity	45 staples
Recommended Ambient Operating Temperature	0°F to 125°F

FUNCTIONAL DESCRIPTION

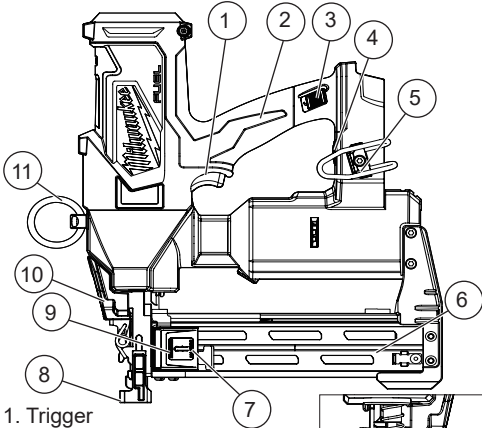

1. Trigger
2. Handle
3. Trigger lock
4. Power button
5. Hook
6. Magazine
7. Pusher release tab
8. Workpiece contact
9. Staple pusher
10. Jam clearing latch
11. Removeable tool hanger ring
12. Depth adjustment

ASSEMBLY

⚠ WARNING Recharge only with the charger specified for the battery. For specific charging instructions, read the operator's manual supplied with your charger and battery.

Removing/Inserting the Battery

To **remove** the battery, push in the release buttons and pull the battery pack away from the tool.

⚠ WARNING Always lock the trigger or remove the battery pack any time the tool is not in use.

To **insert** the battery, slide the pack into the body of the tool. Make sure it latches securely into place.

⚠ WARNING Only use accessories specifically recommended for this tool. Others may be hazardous.

Installing Staples

⚠ WARNING Always remove battery pack before changing or removing staples. Always wear safety goggles or glasses with side shields.

To **install** staples:

1. Pull staple pusher to the bottom of the magazine assuring it locks in place. Load a collation of staples from the rear of the magazine with the legs pointing towards the front of the tool.

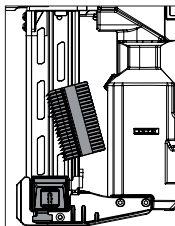

2. The staples will need to be loaded near the bottom of the magazine and then slide into place over the metallic portion.
 - a. Up to 2 full collations can be loaded in the magazine at a time.
3. Once the staples are in the magazine, press the tab on the bottom of the staple pusher to release it from the locked position.
 - a. Do not leave staple pusher in locked position when staples are not being loaded.

Attaching and Removing the Tool Hanger

1. To **attach**, place the hanger ring through the tool hanger.
2. Position the tool hanger on the tool over the two screw holes.
3. Insert the two screws. Hand tighten the screws.
4. To **remove**, reverse the procedure.

OPERATION

⚠ WARNING To reduce the risk of injury, always wear proper eye protection marked to comply with ANSI Z87.1.

When working in dusty situations, wear appropriate respiratory protection or use an OSHA compliant dust extraction solution.

Eye protection does not fit all operators in the same way. Make sure the eye protection chosen has side shields or provides protection from flying debris both from the front and sides. The employer is responsible for enforcing the use of eye protection by the operator and other people in the work area. When required, wear head protection in accordance with ANSI Z89.1.

To reduce the risk of injury to yourself and others, test the tool before beginning work each day according to the "Required Daily Testing" section. Do not use the tool unless you thoroughly understand the actuation mode selected.

Remove battery pack and staples before leaving the work area, moving the tool to another location, or handing the tool to another person. Failure to do so could result in serious injury.

Do not use this tool for fastening electrical cables. It is not designed for electric cable installation and may damage the insulation of electric cables thereby causing electric shock or fire hazards.

NEVER wedge or hold back the workpiece contact mechanism during operation of the tool. Never attempt to clear a jammed workpiece contact by grasping the discharge area of the tool. Doing so could result in serious injury.

To avoid serious injury, do not attempt to prevent the recoil by holding the tool too firmly against the work. Keep face and body away from the tool. During normal use, the tool will recoil immediately after driving a staple. This is a normal function of the tool. Restriction to the recoil can result in a second staple being driven when the tool is in Contact Actuation mode. Grip the handle firmly, let the tool do the work, and do not place a second hand on top of the tool.

Always lock the trigger or remove the battery pack any time the tool is not in use.

① Power Function

1. Install battery pack.
2. Press and hold the Power button ① to turn on the tool (the Power button's green LED ring will light). The Battery LED indicates when the battery level is insufficient to operate the tool.

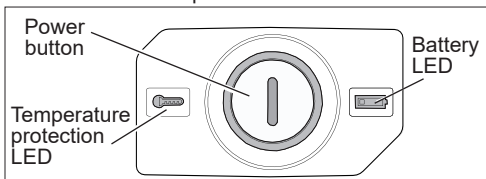

3. Press and hold the Power button ① to turn off the tool.

Temperature Protection Mode

When the tool is turned on at extreme Cold/Hot temperature ranges the tool will enter temperature protection mode to avoid damage to the tool. The tool will not function in this mode and the LED will illuminate blue (cold) or red (hot). Once the temperature is suitable, the tool and LEDs will return to normal operation.

Reload Indicator

To indicate that the magazine is almost empty of staples (about 4-5 left), the workpiece contact will not compress, preventing operation under usual pressure. Install more staples to continue working.

⚠WARNING NEVER wedge or hold back the workpiece contact mechanism during operation of the tool. Never attempt to clear a jammed workpiece contact by grasping the discharge area of the tool. Doing so could result in serious injury.

To avoid serious injury, do not attempt to prevent the recoil by holding the tool too firmly against the work. Keep face and body away from the tool. During normal use, the tool will recoil immediately after driving a staple. This is a normal function of the tool. Restriction to the recoil can result in a second staple being driven when the tool is in Contact Actuation mode. Grip the handle firmly, let the tool do the work, and do not place a second hand on top of the tool.

Setting the Depth of Drive

The depth of drive can be adjusted to account for the size of the staple and the workpiece material.

⚠WARNING Know what is behind your workpiece. A staple could travel through the workpiece and out the other side, striking a bystander and causing serious injury. Lower the depth of drive to prevent the staple from being pushed all the way through the workpiece.

1. Drive a test staple.
2. Remove battery pack.
3. **⚠WARNING!** Always point the tool away from yourself and others when making adjustments. Failure to do so could result in injury.

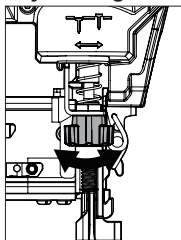

4. Turn the depth selector left or right to increase or decrease the driving depth.
5. Repeat until desired depth is reached.

Clearing a Jammed Staple

Most jams are caused by a staple or part of a staple wedging between the driver blade and the staple guide. Staple strips with an incorrect collation angle or the wrong staple gauge may cause continuous jamming. To clear the jam:

1. Remove battery pack.
2. **⚠WARNING!** Always point the tool away from yourself and others when installing or removing staples. Failure to do so could result in injury.
3. Remove staple strip from magazine.
4. Pull down on the jam latch and pull away from the tool.
5. Remove the staple and other debris (use needle-nose pliers if necessary).
6. Close jam latch.
7. Follow the steps under "Required Daily Testing" before restarting the work.

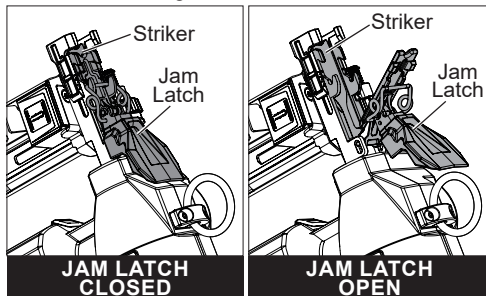

Retracting a Dropped Striker

If the striker becomes "dropped" and does not retract after an operation:

1. Remove battery pack.
2. Remove all staples.
3. Reinsert battery pack.
4. Turn tool ON.
5. Retract staple pusher. ①
6. Press the workpiece contact bracket against a workpiece ②.
7. Pull the trigger ③.

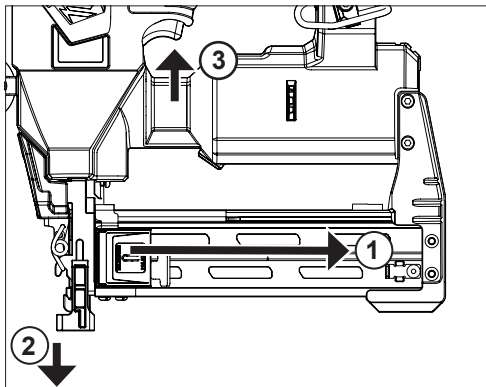

8. The striker will retract.
9. Reload staples according to "Installing Staples".

Trigger Locking Feature

Use the trigger lock feature when tool is not in use. Always use trigger lock when transporting and storing this tool. Failure to do so can result in injury.

To lock/unlock the trigger:

1. **WARNING!** Always point the tool away from yourself and others when installing or removing staples. Failure to do so could result in injury.
2. To lock the trigger, slide the switch up.
3. To unlock the trigger, slide the switch down.

REQUIRED DAILY TESTING

WARNING To reduce the risk of injury to yourself and others, test the tool before beginning work each day or if the tool is dropped, received a sharp blow, been run over, etc. Complete the following checklist **IN ORDER**. If the tool does not work as it should, contact a MILWAUKEE service facility immediately.

Always point tool away from yourself and others.

1. Remove battery pack.
2. **WARNING!** Always point the tool away from yourself and others when installing staples. Failure to do so could result in injury.
3. Check all screws, bolts, nuts, and pins on the tool. Any loose staples must be tightened.
4. Open the magazine (to override the Reload Indicator) and press the workpiece contact against a workpiece. It must move smoothly.
5. With the workpiece contact pressed against the workpiece, pull the trigger. It must move smoothly.
6. Insert battery pack.
7. Without pulling the trigger, open the magazine (to override the Reload Indicator) and press the workpiece contact against a workpiece. The tool must not operate.
Holding the workpiece contact away from the workpiece, open the magazine (to override the Reload Indicator). Pull and hold the trigger for 5 seconds. The tool must not operate.
Continue to pull and hold the trigger and push the workpiece contact against a workpiece. The tool must not operate.
Without pulling the trigger, open the magazine (to override the Reload Indicator) and press the workpiece contact against a workpiece. Pull the trigger. The tool must operate.
Release the trigger. The driver must move up.
8. Holding the workpiece contact away from the workpiece, open the magazine (to override the Reload Indicator) and pull the trigger. The tool must not operate.
Continue to pull and hold the trigger and push the workpiece contact against a workpiece. The tool must operate.
9. If all previous tests work properly, set the tool for your work. Load staple strips.
10. Set the depth of drive according to the "Setting the Depth of Drive" section.
11. If all tests operate properly, the tool is ready for use. Repeat these tests before use each day or if the tool is dropped, received a sharp blow, jammed, etc.

MAINTENANCE

WARNING To reduce the risk of injury, always unplug the charger and remove the battery pack from the charger or tool before performing any maintenance. Never disassemble the tool, battery pack or charger. Contact a MILWAUKEE service facility for ALL repairs.

Maintaining Tool

Keep your tool, battery pack and charger in good repair by adopting a regular maintenance program. Inspect your tool for issues such as undue noise, misalignment or binding of moving parts, breakage of parts, or any other condition that may affect the tool operation. Return the tool, battery pack, and charger to a MILWAUKEE service facility for repair. After six months to one year, depending on use, return the tool, battery pack and charger to a MILWAUKEE service facility for inspection.

If the tool does not start or operate at full power with a fully charged battery pack, clean the contacts on the battery pack. If the tool still does not work properly, return the tool, charger and battery pack, to a MILWAUKEE service facility for repairs.

WARNING To reduce the risk of personal injury and damage, never immerse your tool, battery pack or charger in liquid or allow a liquid to flow inside them.

Cleaning

Clean dust and debris from any vents. Keep tool clean, dry and free of oil or grease. Use only mild soap and a damp cloth to clean, since certain cleaning agents and solvents are harmful to plastics and other insulated parts. Some of these include gasoline, turpentine, lacquer thinner, paint thinner, chlorinated cleaning solvents, ammonia and household detergents containing ammonia. Never use flammable or combustible solvents around tools.

Repairs

For repairs, return the tool, battery pack and charger to the nearest authorized service center.

ACCESSORIES

WARNING Use only recommended accessories. Others may be hazardous.

For a complete listing of accessories, go online to www.milwaukeetool.com or contact a distributor.

SERVICE - UNITED STATES

1-800-SAWDUST (1.800.729.3878)

Monday-Friday, 7:00 AM - 6:30 PM CST

or visit www.milwaukeetool.com

Contact Corporate After Sales Service Technical Support with technical, service/repair, or warranty questions.

Email: metproductsupport@milwaukeetool.com

Become a Heavy Duty Club Member at www.milwaukeetool.com to receive important notifications regarding your tool purchases.

SERVICE - CANADA

Milwaukee Tool (Canada) Ltd

1.800.268.4015

Monday-Friday, 7:00 AM - 4:30 PM CST

or visit www.milwaukeetool.ca